

INSTRUCTION MANUAL

RIDE ON POWER TROWEL

—

BT120-2/5/PFV35.1





Use this guide along with the parts lists attached to locate and identify components of your trowel. When ordering replacement parts, be sure to provide the model number and serial number from the trowel.

Copyright

© Copyright 2011 by Beton Trowel.

Contact

BETON TROWEL
Nijverheidsstraat 10
1840 Londerzeel
BELGIUM
www.betontrowel.com

Nijverheidsstraat 10, 1840 Londerzeel/Belgium
Tel: +32 (0)52 315 350 - Tel: +32 (0)52 315 351 - Fax: +32 (0)52 315 359
E-mail: info@betontrowel.com - www.betontrowel.com
BE 0821.249.312

1. FOREWORD

Quality assurance / machine break in

The Beton Trowel Ride-on Trowel is the product of extensive engineering development designed to give long life and unmatched performance. Once machines are fully assembled, a run-in test is performed to ensure quality standards of the highest level. A series of operational tests are conducted on concrete, incorporating a phase of operations at 1/2 to 3/4 throttle and a final run phase at full throttle for a minimum of 20 minutes.

You can help ensure that your Ride-on will perform at top levels by observing a simple routing on first use. Consider that your new Ride-on Trowel is like a new car. Just as you would break in a new car to the road or any new machine to the job, you should start gradually and build up to full use. Learn what your machine can do and how it will respond. Refer to the engine manufacturer's manual for run-in times. Full throttle and control may be used after this time period, as allowed by material. This will serve to further break in the machine on your specific application, as well as provide you with additional practice using the machine.

We thank you for the confidence you have placed in us by purchasing a Beton Trowel Ride-on Trowel and wish you many years of satisfied use.

2. TABLE OF CONTENTS

1. Foreword	3
2. Table of contents	4
3. Safety Precautions	6
4. Assembly Instructions.....	7
Battery – Shipped dry – No acid	7
Steering handle assembly.....	7
Pitch control Assembly	7
Seat Assembly.....	7
Transporter Assembly.....	7
5. Operating Instructions.....	8
Starting procedures – warm temperatures.....	8
Starting procedures – cold temperatures	8
To Stop engine.....	8
Steering.....	8
Float/Trowel pitch setting	9
Blade synchronization (specially modified units only)	9
Transporter Use.....	9
6. Maintenance.....	10
Preventative maintenance and routine service plan	10
GENERAL.....	10
AIR CLEANER.....	10
SPARK PLUG.....	10
BELT CHANGE PROCEDURE.....	10
BELT TENSIONING SPECIFICATIONS.....	10
Lubrication.....	11
ENGINE OIL	11
SPIDER PLATE.....	11
GEARBOX	11
TO CHANGE GEARBOX OIL.....	11
GREASE FITTINGS.....	11

Maintenance plan.....	12
Service	14
7. Labels.....	15
8. Specifications.....	16
Technical data sheet.....	16
Electrical wiring scheme	17
9. Parts.....	18
Framework.....	18
Guard Ring	20
Power System	22
Steering System	24
Operating System	27
Gearbox Assembly (Left)	30
Gearbox Assembly (Right)	33
Fuel- & Water System.....	36
Clutch assembly.....	38
Declaration of Conformity / Certificat de conformite / Gelijkvormigheidscertificaat / Declaracion de Conformidad / Declaracao de Concormidade / Dichiarazione Di Conformita	39

3. SAFETY PRECAUTIONS

- ❖ Always keep unauthorized, inexperienced, untrained people away from this machine.
- ❖ Rotating and moving parts will cause injury if contacted. Make sure guards are in place. Keep hands and feet away from moving parts.
- ❖ Fuel the machine only when the engine is stopped, using all necessary safety precautions.
- ❖ The engine must always be stopped before attempting any repair or adjustments. Ignition key should be off.



Danger: Never operate the machine in an explosive atmosphere, near combustible materials or where ventilation does not clear exhaust fumes. Repair fuel leaks immediately.

Refer to your engine owner's manual for more safety instructions.

- ❖ Be careful not to come in contact with the muffler when the engine is hot, serious burns may result!
- ❖ Always operate the machine in a seated position to maintain machine balance.
- ❖ The transporter is designed for moving the unit around the job site only. It is not to be used for towing the Ride-On unit off-site.
- ❖ When starting the trowel, do not exceed the ¼ throttle position as recommended. A higher setting could cause the centrifugal clutch to engage, turning the trowel blades.
- ❖ Be careful with the trowel around stub pipes or other obstructions on the floor. Should the machine catch, or hit such an obstruction, serious damage may result to the machine, or operator may be thrown from the machine.
- ❖ Excess surface water may result in sudden loss of control of steering.
- ❖ Disconnect battery before attempting any electrical maintenance.
- ❖ Ensure that the electrical dead-man switch, located on the right hand steering lever is operating. Placing your right hand on the steering lever will engage the safety switch. Removing your hand from the Lever will disengage the safety switch and stop the engine. The engine will not start unless the safety switch is depressed. This safety feature must be used as designed

4. ASSEMBLY INSTRUCTIONS

BATTERY – SHIPPED DRY – NO ACID

Connect and secure the battery cables before attempting starting procedures.

STEERING HANDLE ASSEMBLY

The steering handles are shipped ready to connect.

Position the handles over the handle sleeves so that the set-screws (2 per handle) are lined up with the tapped holes on the sleeves. Tighten the set-screws and test the mobility of the handles.

PITCH CONTROL ASSEMBLY

Bolt pitch control tube (C) to pitch control bracket (D) with bolts provided. Put cable end (E) through yoke arm (F) and secure with nylon insert locknut (G). For proper cable adjustment, turn crank (A) counter-clockwise to the stop position. Tighten nut (G) until all slack in the cable is removed. If more than 2 or 3 threads show through the nut, it should be turned back and the guide screw (B) moved to the next lower hole. Tension in the cable should then be readjusted. After adjusting tension, turn hand crank full clockwise (ABOUT 24 TURNS) and check for clearance between the yoke arm (F) and the gear box at point (H). There should be enough space to pass a business card through but not more than 1/8 inch.

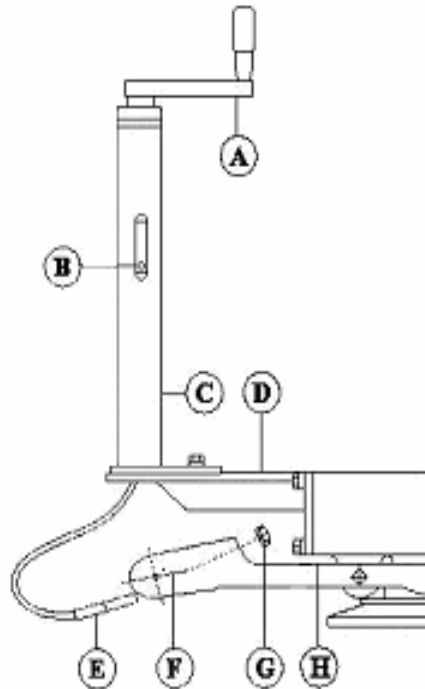

SEAT ASSEMBLY

Remove protective wrapping from seat. The seat is now ready to secure to the frame using included washers and hex nuts. If the seat adjuster is ordered, the slider bars must be positioned between the seat and the frame using included screws to secure the seat to the sliders, and then securing the sliders to the frame as indicated above.

TRANSPORTER ASSEMBLY

The components of the transporter (handle, frame, wheels, and parts bag) are shipped separately, requiring some assembly. Extend the handle outside the frame. Slide the handle along the frame cross-bar to align the hole on the handle with the hole on the “U” frame. Insert the large hitch pin (part #12487) through the hole to secure the handle to the “U” frame. Position one of the wheels on the axle and secure in place by inserting pin (part #10315) into the hole on the end of the axle. Repeat procedure for the other wheel.



CAUTION: The transporter is designed to be used on the job site only. Do not use the transporter to tow the machine off-site.

5. OPERATING INSTRUCTIONS

STARTING PROCEDURES – WARM TEMPERATURES

- ❖ Prior to starting the trowel, check the engine and gearbox oil levels. Be sure the fuel tank is full.
- ❖ Fuel is not shipped with the unit. Check engine and gearbox oil levels. **WARRANTY IS VOID IF RUN WITHOUT OIL.**
Fill tank with safety approved fuel containers. **DO NOT MIX OIL WITH FUEL.**
- ❖ Maintain left foot pressure on the dead-man safety switch. Engine will disengage and stop if safety switch is released. Do not tape, tie-down, or otherwise attempt to bypass safety device..
- ❖ Turn ignition key all the way. Allow engine to warm up before proceeding with full trowel operation.

STARTING PROCEDURES – COLD TEMPERATURES

Follow same procedure as above but allow for a longer warm up period 3-5 min. (In cold weather oil is much heavier to move. Extra time is required to heat the oil.)

TO STOP ENGINE

- ❖ Bring throttle to low idle, wait a few seconds.
- ❖ Remove left foot from dead-man safety switch.
- ❖ Turn off ignition key.

STEERING

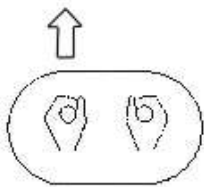

FORWARD

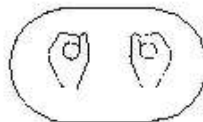

REVERSE

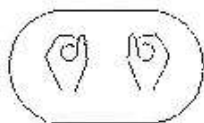

CLOCKWISE

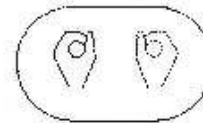

C-CLOCKWISE

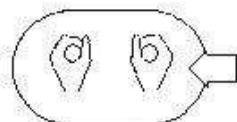

LEFT



RIGHT

Guiding the machine on the slab is quite simple but does require some familiarity before actually working with the machine. The controls respond as shown in figure 2a below. Test the machine on a finished Section of the floor, with the blades in a flat position, and the engine at a low revolution to gain the necessary feel for the steering.

For straight line movement, move both handles as one in the direction you wish to travel. Move the handles in opposite directions to produce rotation on the machines axis. Left handle forward, right handle backward for clockwise rotation. Left handle backward, right handle forward, for counter-clockwise rotation. Sideways direction is achieved by sideways movement of the right handle in the required direction of travel.



WARNING: SERIOUS INJURY OR PROPERTY DAMAGE MAY RESULT DUE TO TEMPORARY LOSS OF CONTROL IF OPERATED WITH EXCESS LIQUID ON THE CONCRETE SURFACE.

FLOAT/TROWEL PITCH SETTING

Once you are familiar with the steering functions on a flat floor, you are ready to combine the steering with float/trowel pitch settings to produce the finish you require. The pitch adjustment feature of the Beton Trowel RIDE-ON TROWEL permits quick and accurate pitch changes of the finishing/float blades, without having to stop the machine. Turning the adjustment crank-handle at the end of the pitch control tubes enables you to change the pitch whenever necessary to allow for varying conditions over the slab surface. Each spider plate is adjusted independently. The pitch setting will affect the steering of your unit. Experiment with the settings as you test drive so you will know what to expect.



CAUTION: Do not let the machine stand in one spot on the soft concrete; This may place unnecessary strain on the clutch to break it free of the concrete. If the unit has been sitting for any length of time, break it free from the concrete before attempting operation.



CAUTION: When finishing concrete above grade, erect a situation barrier along the edge of the slab as a protective measure. The barrier must follow all applicable codes and should be such that it will stop the trowel from riding over the edge of the slab in case of loss of control.

BLADE SYNCHRONIZATION (SPECIALLY MODIFIED UNITS ONLY)

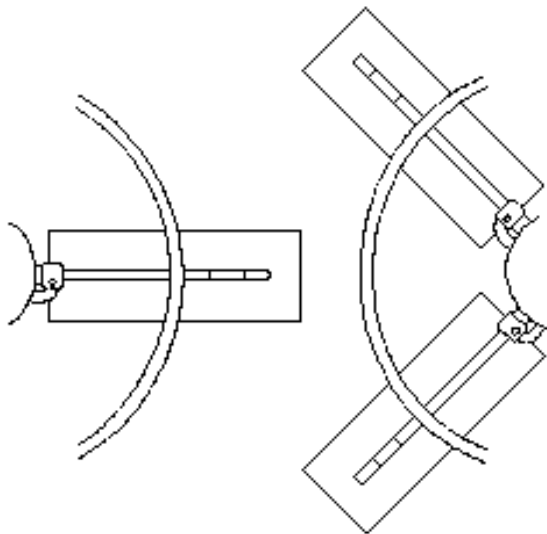

To avoid blades hitting, make sure spider plates are positioned as shown with respect to each other after performing any maintenance.

TRANSPORTER USE



The transporter is designed to be used on the job site only. Do not use it to tow the machine offsite. The transporter has pick-up brackets located on the inside of the wheels which should be positioned under the pick-up points on the frame. Before connection, the handle will be pointing upwards at approximately a 45 degree angle. Pull the handle down, engaging the transporter and secure the bracket and transporter to the frame by locking the handle bracket in the frame lock by means of the hitch pin. Using the handle as a lever, the ride-on may now be moved. To disconnect the transporter, follow the above steps in reverse.

6. MAINTENANCE

PREVENTATIVE MAINTENANCE AND ROUTINE SERVICE PLAN

This trowel has been assembled with care and will provide years of service. Preventative maintenance and routine service are essential to the long life of your trowel. Your dealer is interested in your new machine and has the desire to help you get the most value from it. After reading through this manual thoroughly, you will find that you can do some of the regular maintenance yourself. However, when in need of parts or major service, be sure to see Beton Trowel.

GENERAL

- Keep engine oil clean. Change according to engine manufacturer's specifications.
- Maintain the oil levels in the engine and gearbox assemblies. Change as required.
- Use only clean fuel in the engine.
- Check for loose nuts and bolts on the trowel and tighten as necessary.
- Check "V" belts for wear, replace if worn.
- Grease all fittings daily. See diagram.
- Clean the unit after every use to prevent hardening of concrete residue. Hard concrete is very difficult to remove, greatly increases weight and reduces efficient subsequent operation of unit.
- Check clutch linings regularly for wear. Linings should be changed when 3/4 worn. Do not allow metal to metal contact as this will damage the clutch drum. (New lining is 8mm.)

AIR CLEANER

Maintaining a clean engine will extend engine life. Keep air filter clean at all times. Clean air filter using the recommended solvent. See engine manual for proper cleaning procedure. Let the filter dry before reinstalling.

SPARK PLUG

Check and clean spark plugs regularly. A fouled, dirty spark plug causes hard starting and poor engine performance. Set spark plug gap to recommended clearance. Refer to engine manual.

BELT CHANGE PROCEDURE

Remove belt cover from the machine to expose the drive components. To change the primary drive belt, remove clutch from engine drive shaft, by removing bolt from the clutch. This releases belt from both the clutch and driven unit.

BELT TENSIONING SPECIFICATIONS



NOTE: Belts may become slightly loose after the first few hours of operation. It is important to retention the belts with the tool provided and use the table given as reference.

LUBRICATION

ENGINE OIL

The long life and successful operation of any piece of machinery is dependent on frequent and thorough lubrication.

Before using the trowel, always check your engine for oil. Use proper engine oil as recommended in the engine manufacturer's manual. Fill crankcase to levels as recommended.

SPIDER PLATE

There are 8 (eight) grease fittings on the spider plates, 4 (four) on each must be greased daily.
SPIDER PLATES MUST BE GREASED EVERY TIME MACHINE IS USED.

GEARBOX

Check the oil level sight plugs on both gearboxes daily to ensure the oil is half way on the sight glass. Top up with Agma 8 compounded gear oil only. Gearbox capacity on the BT900 is 27oz./767ml.

TO CHANGE GEARBOX OIL

Place a pan beneath the drain plug to catch the oil. Remove the drain plug and the filler plug from the gearbox. After the oil has drained completely, replace the drain plug and tighten. Fill the gearbox through the filler plug with 27oz./767ml. of Agma 8 compounded gear oil. Replace the filler plug and tighten.

GREASE FITTINGS

There are 6 bearings in total. Grease all bearings and U-joints to ensure adequate supply of lubricant. They are located above the gearboxes (2 per gearbox) and 2 located in the drive system. The U-joints are located in the drive system as well

MAINTENANCE PLAN

Routine Service Intervals - Continued -		Each use	After 1.5 months or 50 hrs	Each 3 months or 100 hrs	Each 6 months or 200 hrs	Each 9 months or 300 hrs	Each 12 months or 400 hrs
Drive Train:							
Bearings	Lubricate	o	o	o	o	o	o
Universal couplings	Lubricate			o	o	o	o
Belt tension / Condition	Check	o	o	o	o	o	o
Clutch / Pulley operation	Check	o	o	o	o	o	o
LH spider plate assembly	Check	o		o	o	o	o
	Lubricate	o	o	o	o	o	o
RH spider plate assembly	Check	o		o	o	o	o
	Lubricate	o	o	o	o	o	o
Gearboxes:							
LH Gearbox oil	Check Level	o	o	o	o	o	o
	Change				o		o
RH Gearbox oil	Check Level	o	o	o	o	o	o
	Change				o		o
Gearbox breathers	Check operation			o	o	o	o
Retardant Spray System:							
Water pump operation	Check	o	o	o	o	o	o
Spray nozzles	Clean	o					
Retardant Fluid	Check levels	o					





Routine Service Intervals		Each use	After 1.5 months or 50 hrs	Each 3 months or 100 hrs	Each 6 months or 200 hrs	Each 9 months or 300 hrs	Each 12 months or 400 hrs
General Inspection:							
Operation of lights	Check		o	o	o	o	o
Battery	Clean & Check			o	o	o	o
	Recharge			o	o	o	o
	Replace						2 yrs
Guards	Check	o	o	o	o	o	o
Warning stickers	Check		o	o	o	o	o
Test run:	Check operation		o	o	o	o	o
Controls:							
Dead-man switch operation	Check	o	o	o	o	o	o
Throttle pedal operation	Check	o	o	o	o	o	o
Steering linkages	Check	o	o	o	o	o	o
	Lubricate		o	o	o	o	o
	Replace						As req'd
Pitch control levers	Check	o	o	o	o	o	o
	Lubricate		o	o	o	o	o
Joystick controls (N/A)	Check	o					
Hydraulic system (N/A)	Check levels			o	o	o	o
	Check hoses			o	o	o	o
	Replace hoses						2 yrs
Engine:							
Fuel pipes & clamps	Check		o	o	o	o	o
	Replace						2 yrs
Engine oil	Check Level	o	o	o	o	o	o
	Change		o		o		o
Engine oil filter	Replace				o		o
Oil cooler	Clean			o	o	o	o
Cooling Fins	Clean		o	o	o	o	o
Air cleaner	Check - clean	o	o	o	o	o	o
	Replace						o
Air Intake Line	Check				o		
	Replace						2 yrs
Fan Belt	Check tightness				o		o
	Replace						500 hrs
Valve clearance	Check-adjust				o		o
Fuel filter	Check & Clean			o	o	o	o
	Replace				o		o
Fuel Tank	Clean						500 hrs
Fuel Injection Nozzles	Check pressure						500 hrs
Fuel Injection Timer	Check						500 hrs
Injection Pump	Check						500 hrs
Engine wiring	Check						o

SERVICE

Due to the nature and environment of use, power trowels are exposed to severe operating conditions. Some general maintenance guidelines will extend the useful life of your trowel.

- ❖ The initial service for your power trowel should be performed after 25 hours of use, at which time your mechanic (or authorized repair shop) should complete all of the recommended checks in the schedule above.
- ❖ Regular service according to the schedule above will prolong the life of the power trowel and prevent expensive repairs.
- ❖ Keeping your power trowel clean and free from concrete residue is the single most important regular maintenance operation, over and above the checks in the service schedule above, that can be performed.
- ❖ Components such as oil seals, belts, drive line parts and bearings are prone to premature wear from exposure to concrete residue. Using a spray-on release agent on your power trowel before each use will make clean-up after use easy and extend the time between replacement of most of the wearing components of the machine.
- ❖ After each use your power trowel should be cleaned to remove any concrete residue from the undercarriage and surrounding components. Use of a power washer will make clean up quick and easy, especially if a release agent was applied prior to use.
- ❖ In the Service Schedule above, items that should be checked, replaced or adjusted are indicated by "o" in the appropriate column. Not all power trowel models include the same features and options and as such not all service operations may have to be performed. For ease of recording place a checkmark (✓) through the "o" when the item is complete. If an item is not required or not completed place an "x" through the "o" in the box.
- ❖ For all fuel-line powered trowels the governed speed of the engine is 2000 to 3600 rpm. See engine manufacturer's manual for exact specifications. Care should be used when making any adjustments to the power trowel not to change the governed speed. Increasing the governed speed of the engine may lead to premature failure and void the manufacturer's warranty.
- ❖ Failure to have your power trowel regularly serviced and properly maintained in accordance with the manufacturer's instructions will lead to premature failure and void the warranty.

7. LABELS

SAFETY PRECAUTIONS	
	<p>! DANGER</p> <p>EXPLOSION HAZARD Never operate the machine in an explosive atmosphere, near combustible materials or where ventilation does not clear exhaust fumes.</p>
	<p>WARNING</p> <p>BURN HAZARD Never come into contact with the engine or muffler when engine is operating or shortly after it is turned off. Serious burns may occur.</p>
	<p>! CAUTION</p> <p>ROTATING HAZARD Never place hands or feet inside safety guard rings. Serious injury will result from contact with rotating blades.</p>
	<p>! CAUTION</p> <p>MOVING PARTS Before starting the machine ensure that all guards and safety devices are in place and functioning properly.</p>
	<p>! ATTENTION</p> <p>READ OWNERS MANUAL Read and understand operator's manual before using this machine. Failure to follow operating instructions could result in serious injury or death.</p>

8. SPECIFICATIONS

TECHNICAL DATA SHEET

MODEL	BT120-2/5/PFV35.1
OPERATING WIDTH	2540 MM
ENGINE MOTOR	Vanguard
LIGHTS & RETARDANT SPRAY	STANDARD
BLADE SIZE	6 " X 18 "
FLOAT PAN SIZE	1170 MM
WEIGHT	480 KG

ELECTRICAL WIRING SCHEME

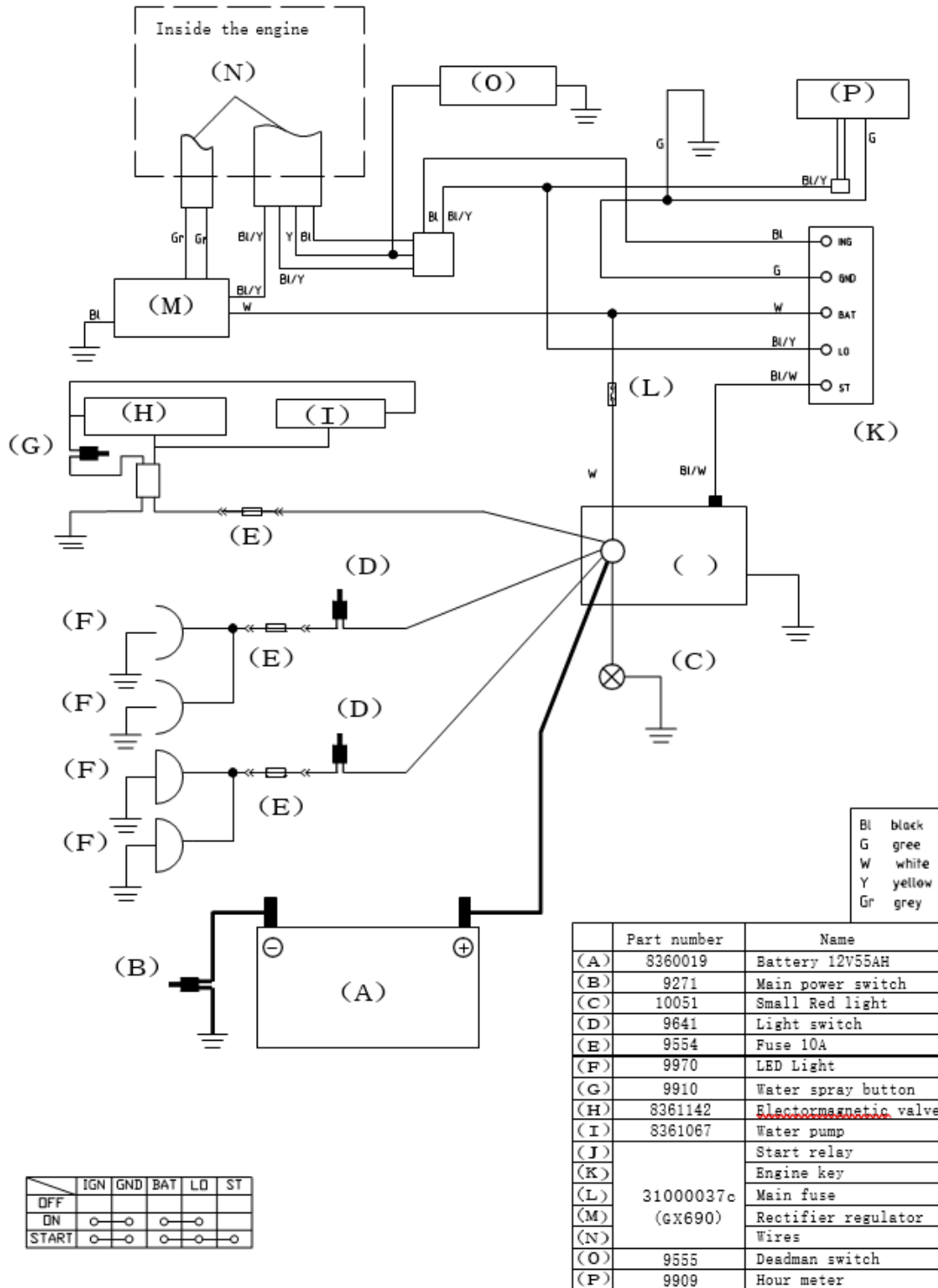

9. PARTS

FRAMEWORK

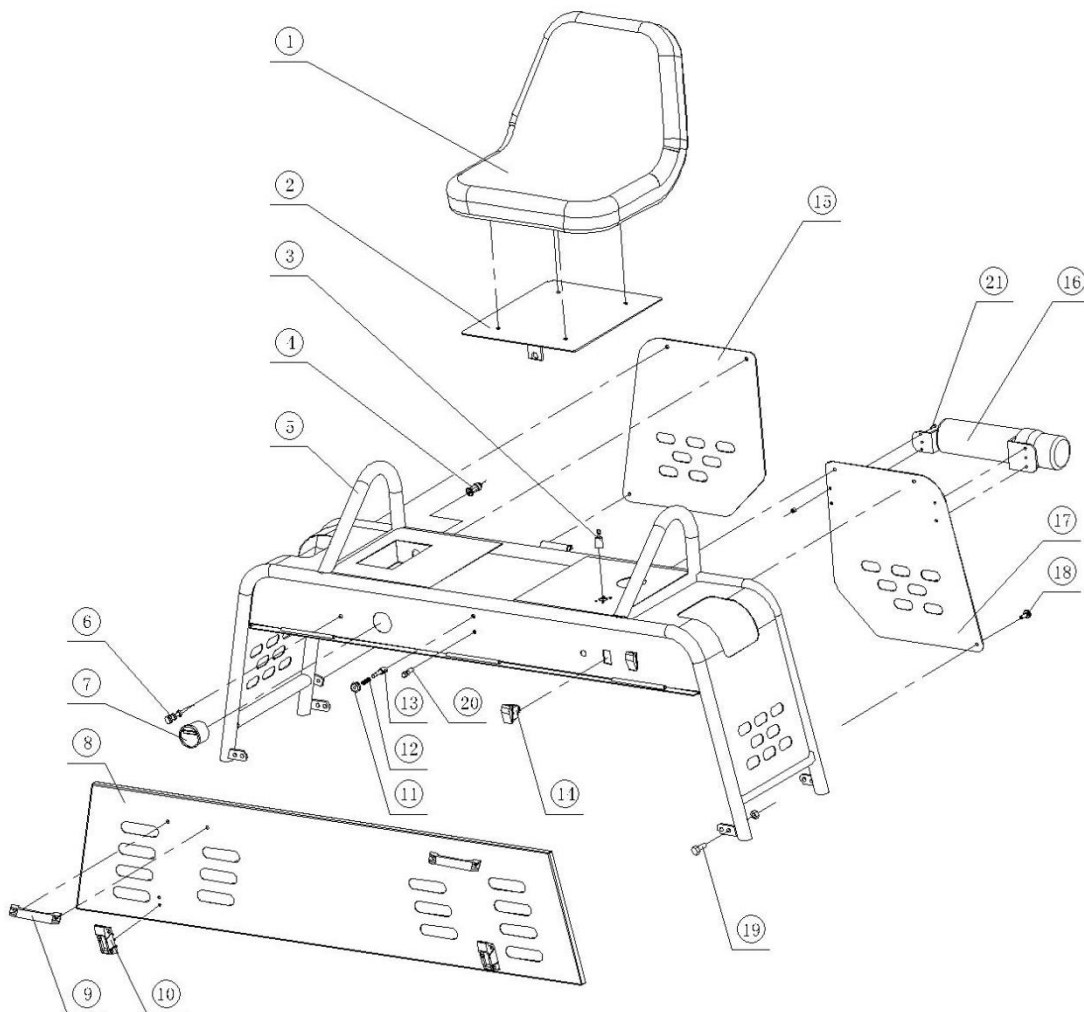

Item No.	Part No.	Description	Qty.
1	8360453	SEAT	1
2	846G8200	SEAT PLATE	1
3	9271	BLOCKING SWITCH	1
4	9334	USD CHARGER	1
5	846G8100	UPPER FRAME	1
6	846A080030	CHOCK ASSY	1
7	9909	HOUR METER	1
8	846G8405	FRONT PANEL	1
9	9678	GRIP	2
10	9346	QUICK RELEASE HASP	2
11	1046H8301	SEAT FASTENER	1
12	1046H8304	SPRING	1
13	1046H8302	PIN	1
14	9641	LIGHT SWITCH	1
15	846G8413	PANEL	1
16	9593	MANUAL HOLDER	1
17	846G8412	PANEL	1
18	9121	LOCKING KNOB	1
19	9018	BOLT	8
	9016	NUT	8
20	10051	INDICATOR LIGHT	1
21	9220	BOLT	4
	9023	NUT	4

GUARD RING

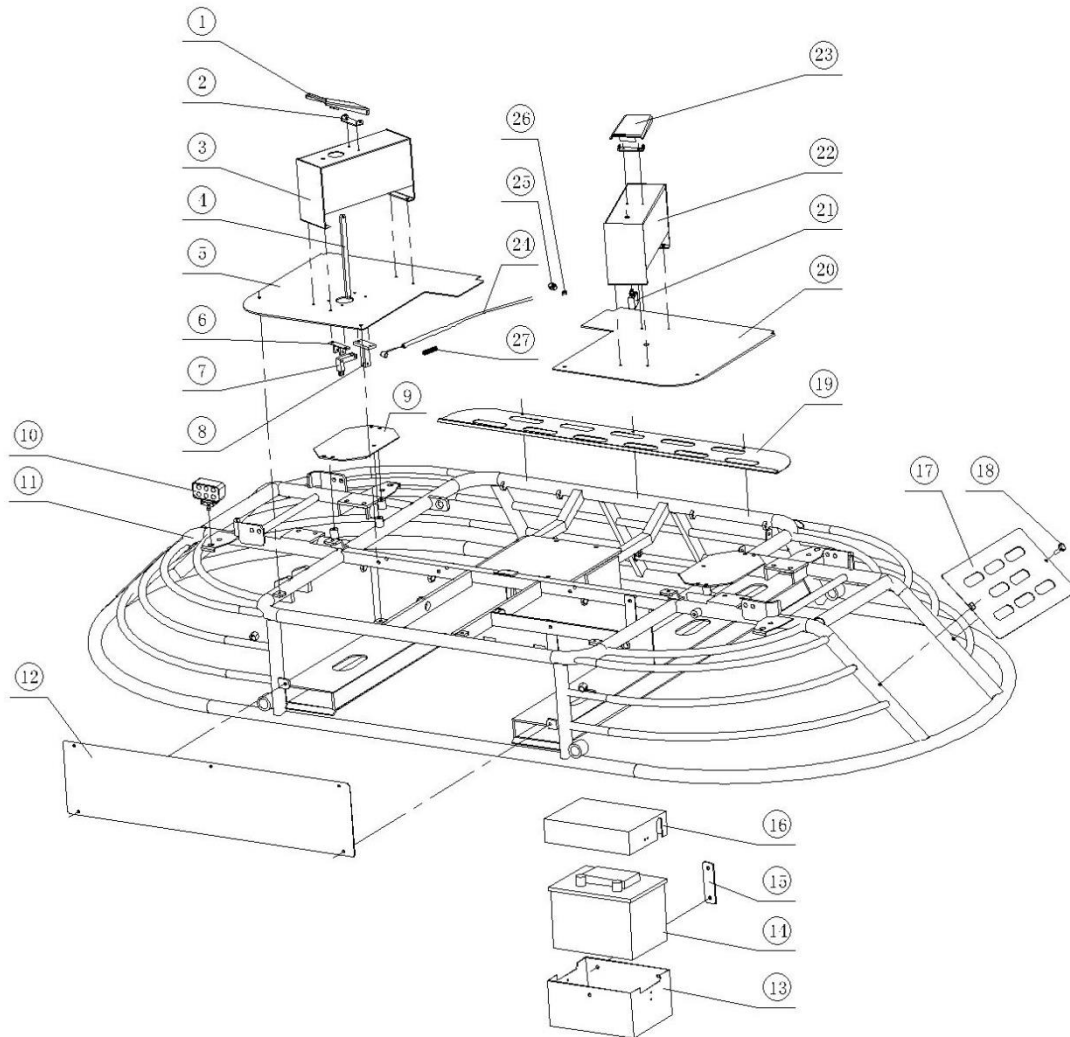

Item No.	Part No.	Description	Qty.
1	8360592a	THROTTLE PEDAL	1
2	8360592C	PEDAL CONNECTING	2
3	846G4200	SUPPORT	1
4	846G4001	CONNECTING ROD	1
5	846G8408	PLATE	1
6	8361426	CONNECTOR	1
7	8361431	CONNECTOR	1
8	8361428	CONNECTOR	1
9	846G7111	PLATE	2
10	9970	LED LIGHT	4
11	846G1100	GUARD RING	1
12	846G8404	PANEL	1
13	8360464	BATTERY BOX	1
14	8360019	BATTERY	1
15	846G8401	CONNECTING PLATE	3
16	8360463	BOX COVER	1
17	846G8402	PANEL	2
18	10053	LOCKING KNOB	4
19	846G8409	PANEL	1
20	846G8407	PLATE	1
21	9555	SAFETY SWITCH	1
22	846G4300	SUPPORT	1
23	8361062a	SAFETY SWITCH PEDAL	1
24	8361450	THROTTLE CABLE	1
25	10052	CABLE HOLDER	1
26	10007	CIRCLIP	1
27	9411	SPRING	1

POWER SYSTEM

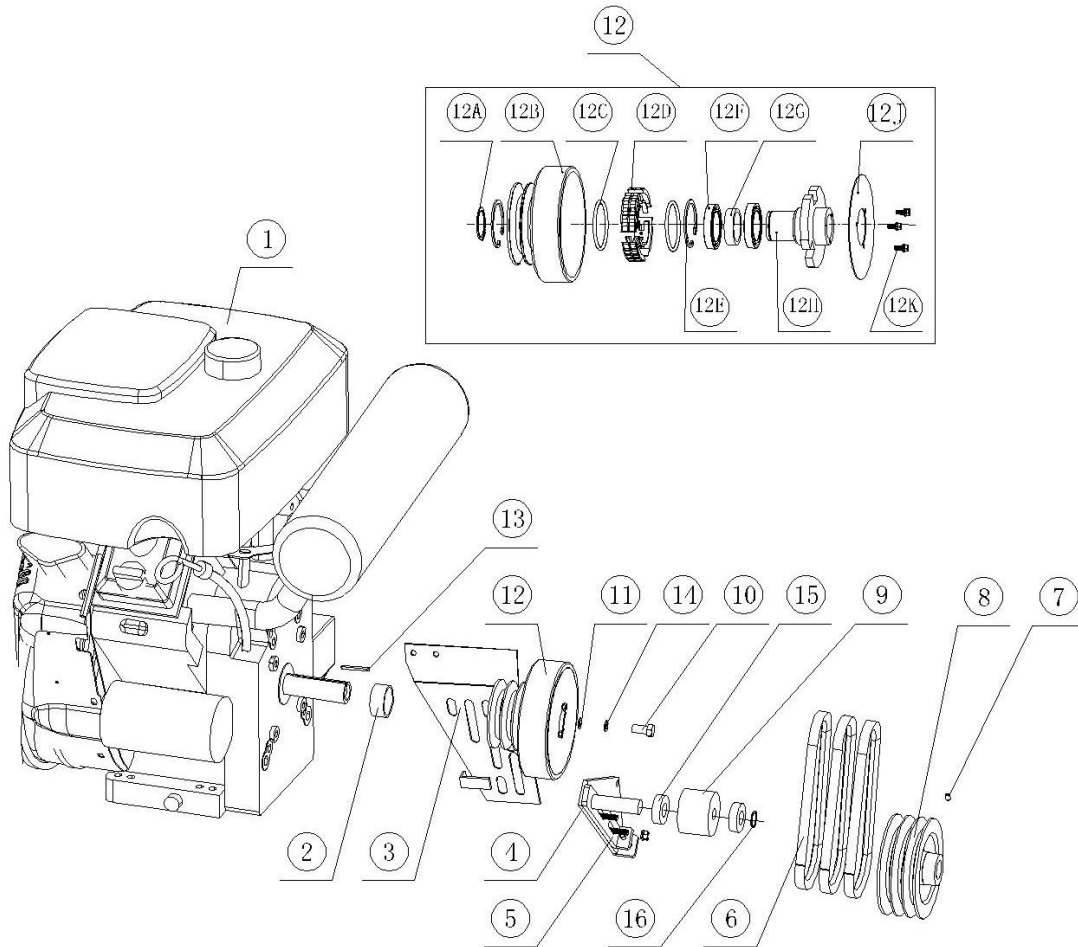

Item No.	Part No.	Description	Qty.
1	31000032	VANGUARD 35HP	1
2	846A030005	BUSHING	1
3	846G8500	BELT GUARD	1
4	846G3100	TENSIONER MOUNTING	1
5	846A030200	TENSIONER ADJUSTING	1
6	9974	BELT	3
7	9101	SCREW	2
8	846G3002	PULLEY	1
9	846A030003	TENSIONER	1
10	8360529	BOLT	1
11	846A030006	SPACER	1
12	84603A0	CLUTCH	1
12A	9471	CIRCLIP	1
12B	84603A1	CLUTCH BODY	1
12C	84603A7	SPRING	2
12D	84603A3Z4	SHOES ASSY	1
12E	9472	CIRCLIP	2
12F	9470	BEARING	2
12G	846A030403	BUSHING	1
12H	84603A2	SHOES HOLDER	1
12J	84603A5	COVER	1
12K	9220	BOLT	3
	9022	SPRING WASHER	3
	9219	WASHER	3
13	9155	KEY	1
14	8360064	SPRING WASHER	1
15	9075	BEARING	2
16	9463	CIRCLIP	1

STEERING SYSTEM

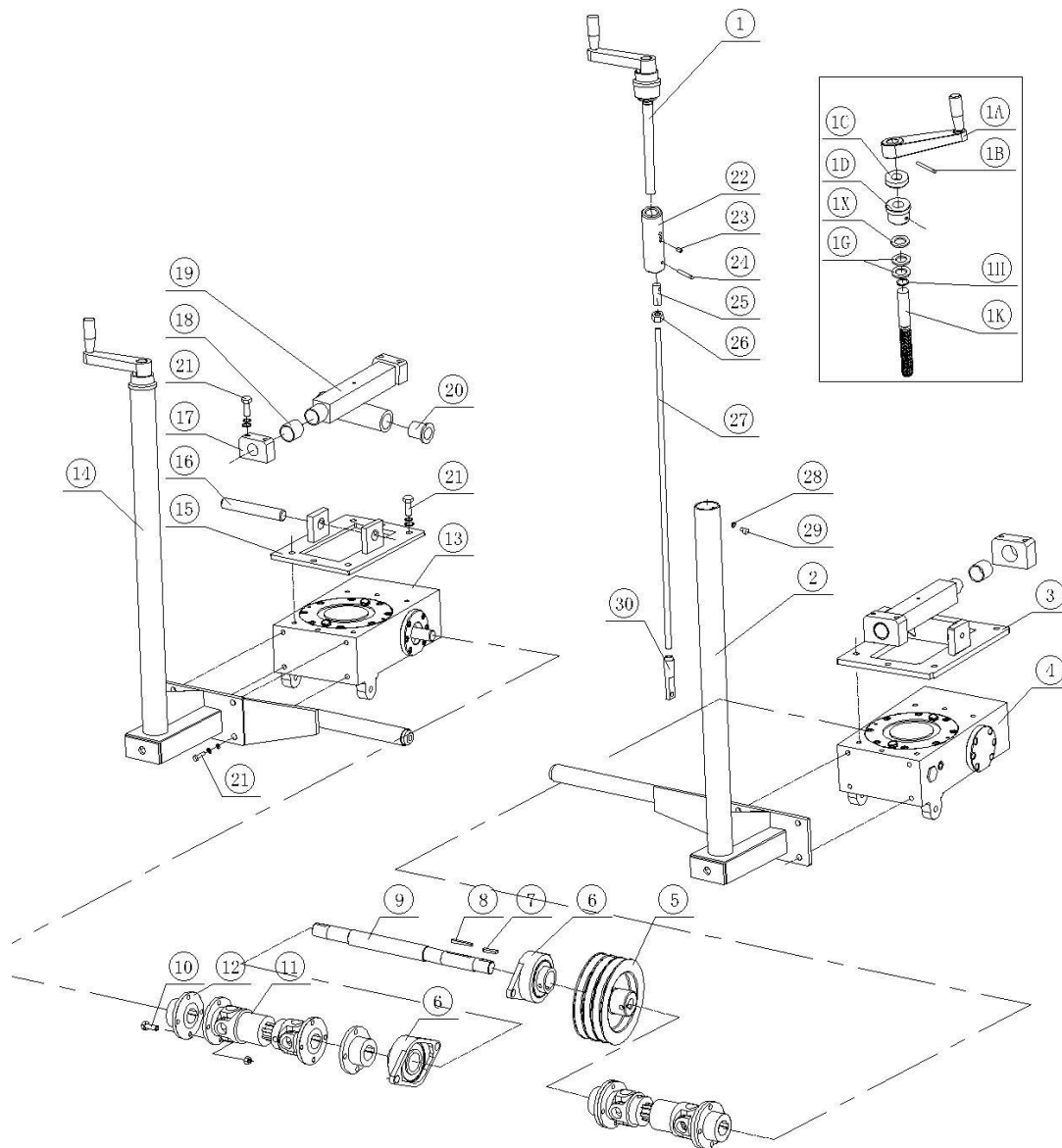

Nijverheidsstraat 10, 1840 Londerzeel/Belgium
 Tel: +32 (0)52 315 350 - Tel: +32 (0)52 315 351 - Fax: +32 (0)52 315 359
 E-mail: info@betontrowel.com - www.betontrowel.com
 BE 0821.249.312

Item No.	Part No.	Description	Qty.
1	846A055000	PITCH CONTROL ASSY	2
1A	B8360470	PITCH HANDLE	2
1B	9157A	PIN	2
1C	9025	BEARING	2
1D	846A050004	BUSHING	2
1G	4365504	SPACER	4
1H	9027	CIRCLIP	2
1K	4365503	THREADED SHAFT	2
1X	9033	WASHER	2
2	846G5400	BRACKET, LEFT	1
3	846G5100	HANGING BRACKET, LEFT	1
4	846A060000L	GEARBOX, LEFT	1
5	846G3002	PULLEY	1
6	9465	BEARING	2
7	9707	KEY	2
8	9706	KEY	1
9	846A030001	INTERMEDIATE SHAFT	1
10	9701	BOLT	16
11	846A030300	COUPLING	2
12	846A030004	FLANGE	4
13	846A060000R	GEARBOX, RIGHT	1
14	846G5500	BRACKET, RIGHT	1
15	846G5200	HANGING BRACKET, RIGHT	1
16	846A050001	SHAFT	1
17	1046H5108	SHAFT BASE	4
18	9634	BEARING	4
19	836G5300	CROSS SHAFT	1
20	846A050107	BUSHING	2
21	9018	BOLT	20
	9047	WASHER	20
	9046	SPRING WASHER	20
22	846A050006	BUSHING	2
23	9028	SCREW	2
24	9610	PIN	2
25	846A050008	CONNECTOR	2
26	9091	NUT	4

27	846A050005	ROD	2
28	9022	SPRING WASHER	2
29	9093	BOLT	2
30	846A050007	CONNECTOR	2

OPERATING SYSTEM

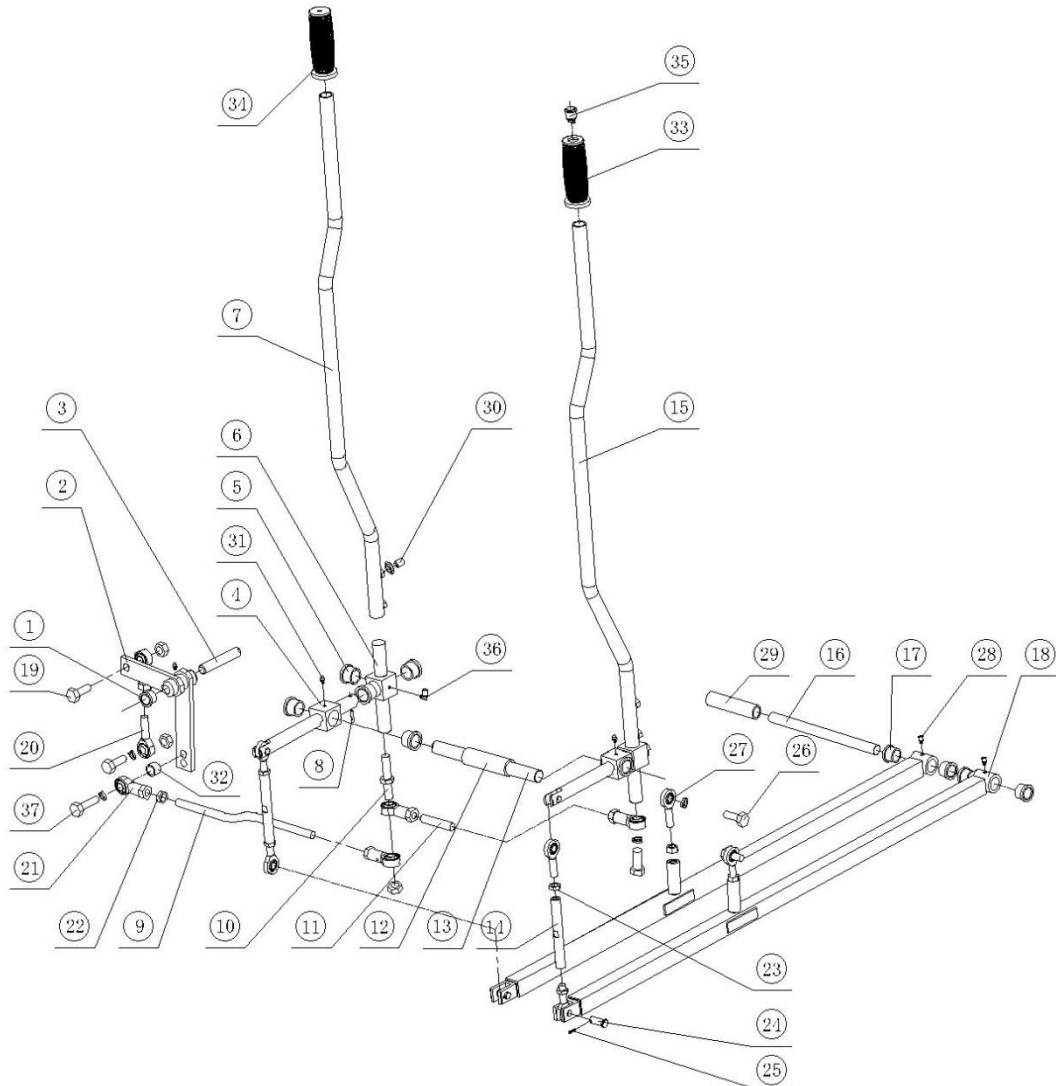

Item No.	Part No.	Description	Qty.
1	8361194	BUSHING	2
2	846G2200	PLATE	1
3	846A020003	SHAFT	1
4	846A020007	HUB	2
5	846A020008	BUSHING	8
6	846A020006	HUB	2
7	836G2400	DRIVE LEVER, RIGHT	1
8	9157A	PIN	2
9	846G2501	ROD	1
10	846A020011	STUD	1
11	846A020010	ROD	1
12	846A020002	BUSHING	1
13	846G2601	SHAFT	1
14	846A020009	ROD	2
15	846G2300	DRIVE LEVER, LEFT	1
16	846A020005	SHAFT	1
17	846A020105	BUSHING	4
18	846G2100	CONNECTING LEVER	2
19	9702	BOLT	3
	9513	NUT	4
20	9500	BEARING	1
21	9501	BEARING	5
22	9514	NUT	4
23	9168	NUT	6
24	9505	PIN	4
25	9506	PIN	4
26	9703	BOLT	2
	9509	SPRING WASHER	2
	9168	NUT	2
27	9464	BEARING	6
28	9502B	GREASE NIPPLE	2
29	846A020001	BUSHING	1
30	9101	SCREW	10
	9112	NUT	4
31	9502	GREASE NIPPLE	3
32	B8360240	BUSHING	1
33	9035G2	GRIP	1
34	9035G1	GRIP	1

35	9910	WATER BUTTON	1
36	9502C	GREASE NIPPLE	2
37	9511	BOLT	1
	9504	SPRING WASHER	3

GEARBOX ASSEMBLY (LEFT)

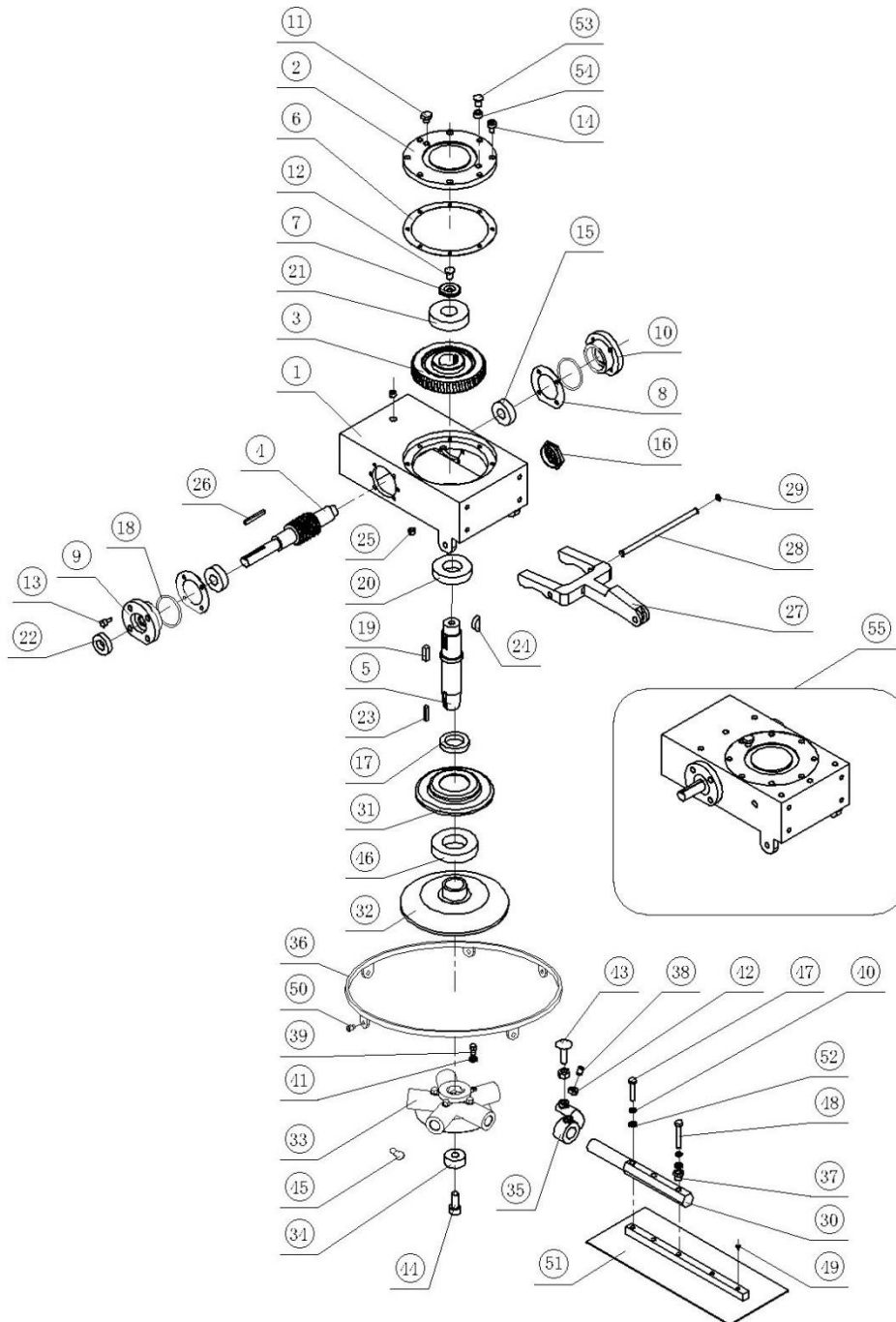

Item No.	Part No.	Description	Qty.
1	846A060001	GEARBOX CASING, LEFT	1
2	846A060003	GEARBOX COVER	1
3	846A060100	BRONZE GEAR, LEFT	1
4	846A060009	COUNTER SHAFT, LEFT	1
5	846A060005	MAIN SHAFT, LEFT	1
6	846A060011	SHIMMING	1
7	846A060004	PRESSURE WASHER	1
8	846A060012	SHIMMING	2
9	846A060007	BEARING FLANGE	1
10	846A060008	BEARING FLANGE	1
11	4364100	RELEASE VALVE	1
12	4364007	BOLT	1
13	9043	BOLT	12
14	9118	BOLT	8
15	9466	BEARING	2
16	9064	SIGHT GLASS	1
17	9368	SEAL	1
18	9367	SEAL	2
19	9708	KEY	1
20	9468	BEARING	1
21	9467	BEARING	1
22	9366	SEAL	1
23	9710	KEY	1
24	9156	KEY	1
25	9053	SCREW	2
26	9709	KEY	1
27	846A050003	YOKE ARM	1
28	846A050002	SHAFT, YOKE ARM	1
29	9202	CIRCLIP	2
30	846A070001	TROWEL ARM	5
31	846A070002	PRESSURE PLATE COVER	1
32	846A070003	PRESSURE PLATE	1
33	1046A070004	SPIDER PLATE, LEFT	1
34	846A070006	BUSHING	1
35	4466006	LIFT ARM	5
36	1046A6103I	STABILIZER RING	1
37	4366007	ADJUST BUSHING	5

38	9540	SCREW	5
39	9066	BOLT	5
40	9037	SPRING WASHER	10
41	9046	SPRING WASHER	5
42	9059	NUT	10
43	9067	SCREW	5
44	9068	SCREW	1
45	9069B	GREASE NIPPLE	5
46	9469	BEARING	1
47	9040	BOLT	10
48	9215	BOLT	5
49	9072	PLUG	5
50	9147	SCREW	10
51	4466100G	BLADE	5
52	9038	WASHER	15
53	846A060013	RELEASE VALVE	1
54	846A060014	NUT	1
55	846A060000L	GEARBOX, LEFT	1

GEARBOX ASSEMBLY (RIGHT)

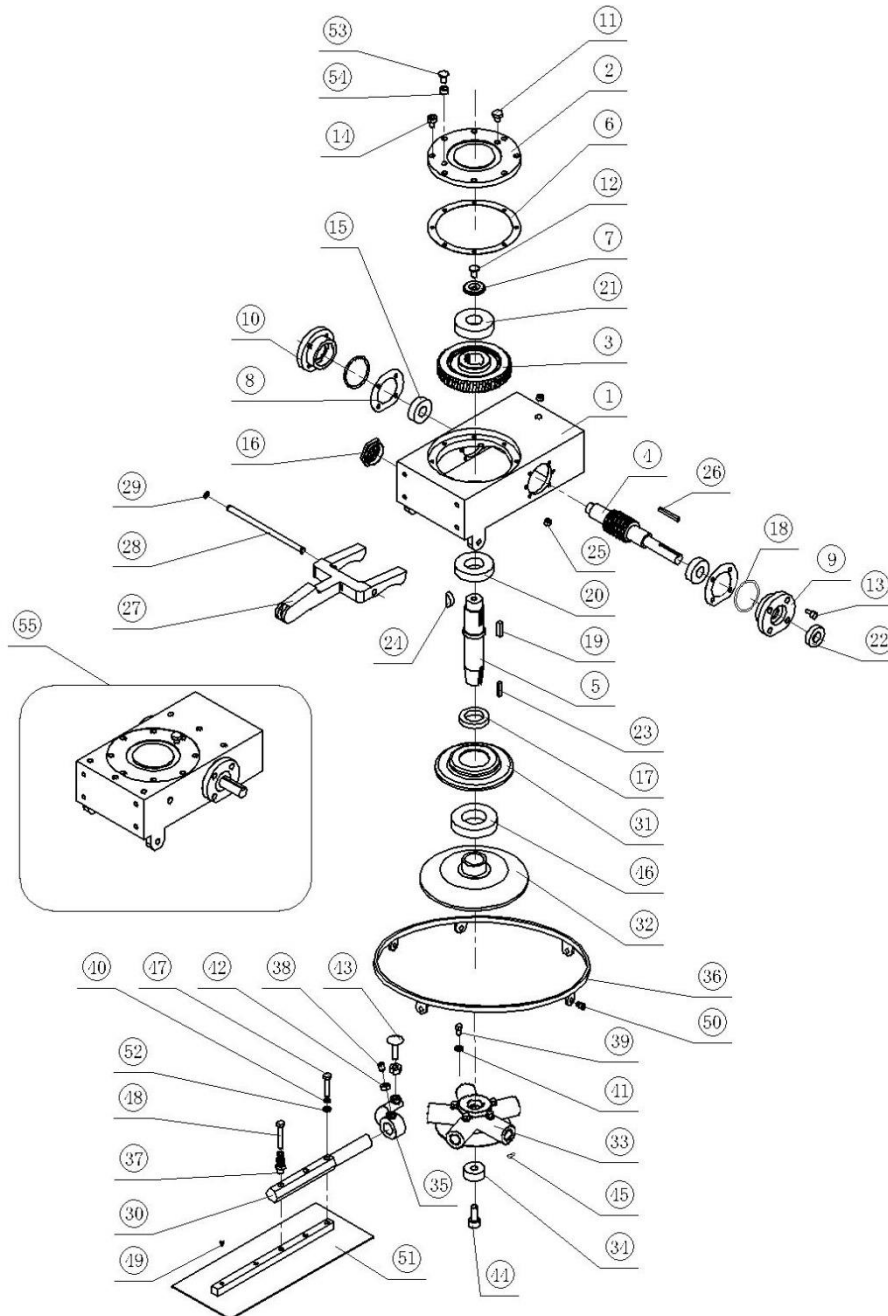

Nijverheidsstraat 10, 1840 Londerzeel/Belgium
 Tel: +32 (0)52 315 350 - Tel: +32 (0)52 315 351 - Fax: +32 (0)52 315 359
 E-mail: info@betontrowel.com - www.betontrowel.com
 BE 0821.249.312

Item No.	Part No.	Description	Qty.
1	846A060002	GEARBOX CASING, RIGHT	1
2	846A060003	GEARBOX COVER	1
3	846A060200	BRONZE GEAR, RIGHT	1
4	846A060010	COUNTER SHAFT, RIGHT	1
5	846A060006	MAIN SHAFT, RIGHT	1
6	846A060011	SHIMMING	1
7	846A060004	PRESSURE WASHER	1
8	846A060012	SHIMMING	2
9	846A060007	BEARING FLANGE	1
10	846A060008	BEARING FLANGE	1
11	4364100	RELEASE VALVE	1
12	9145	BOLT	1
13	9043	BOLT	12
14	9118	BOLT	8
15	9466	BEARING	2
16	9064	SIGHT GLASS	1
17	9368	SEAL	1
18	9367	SEAL	2
19	9708	KEY	1
20	9468	BEARING	1
21	9467	BEARING	1
22	9366	SEAL	1
23	9710	KEY	1
24	9156	KEY	1
25	9053	SCREW	2
26	9709	KEY	1
27	846A050003	YOKE ARM	1
28	846A050002	SHAFT, YOKE ARM	1
29	9202	CIRCLIP	2
30	846A070001	TROWEL ARM	5
31	846A070002	PRESSURE PLATE COVER	1
32	846A070003	PRESSURE PLATE	1
33	1046A070005	SPIDER PLATE, RIGHT	1
34	846A070006	BUSHING	1
35	8366006	LIFT ARM	5
36	1046A6103I	STABILIZER RING	1
37	4366007	ADJUST BUSHING	5

38	9540	SCREW	5
39	9066	BOLT	5
40	9037	SPRING WASHER	10
41	9046	SPRING WASHER	5
42	9059	NUT	10
43	9067	SCREW	5
44	9068	SCREW	1
45	9069B	GREASE NIPPLE	5
46	9469	BEARING	1
47	9040	BOLT	10
48	9215	BOLT	5
49	9072	PLUG	5
50	9147	SCREW	10
51	4466100G	BLADE	5
52	9038	WASHER	15
53	846A060013	RELEASE VALVE	1
54	846A060014	NUT	1
55	846A060000R	GEARBOX, RIGHT	1

FUEL- & WATER SYSTEM

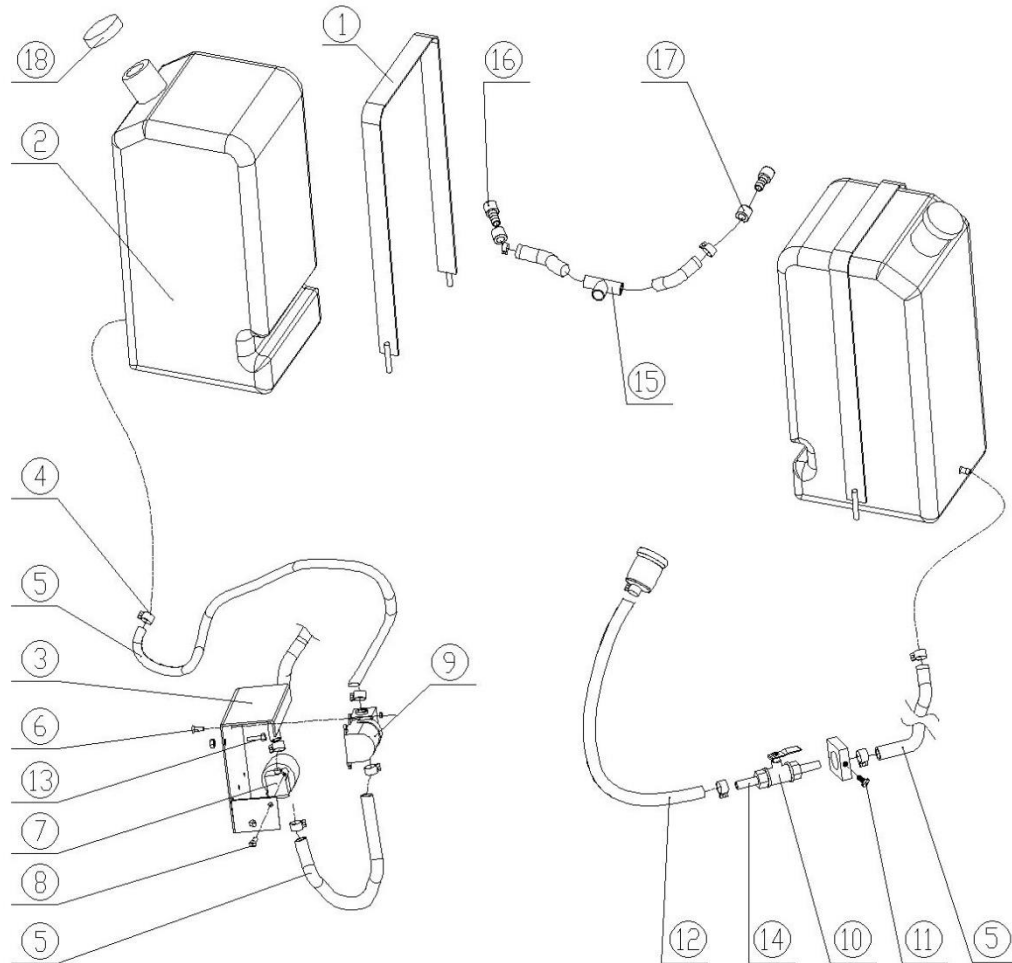

Item No.	Part No.	Description	Qty.
1	FT8360710	TANK HOOP	2
2	B8361073PL	WATER/FUEL TANK	2
3	B8360731	MOUNTING PLATE	1
4	8361071	JOINT	12
5	10202003	WATER PIPE	6
6	9516	SCREW	4
	9517	NUT	4
7	8361142	SOLENOID PILOT ACTUATED VALVE	1
8	9230	SCREW	2
	9128	SPRING WASHER	2
9	8361067	WATER PUMP	1
10	8361476	VALVE	1
11	9010	BOLT	1
12	10202004	FUEL PIPE	1
13	9220	BOLT	2
	9023	NUT	2
14	8361476A	JOINT	2
15	9571	JOINT	1
16	846A080010	WATER NOZZLE	2
17	9231	VALVE	2
18	8360199B	TANK CAP	2

CLUTCH ASSEMBLY

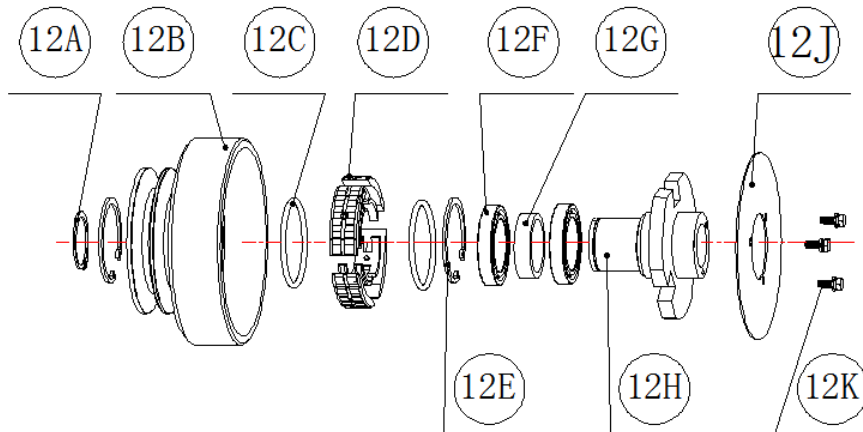

Item No.	Part No.	Description	Qty.
12A	9471	CIRCLIP	1
12B	84603A1	CLUTCH BODY	1
12C	84603A7	SPRING	2
12D	84603A3Z4	SHOES ASSY	1
12E	9472	CIRCLIP	2
12F	9470	BEARING	2
12G	846A030403	BUSHING	1
12H	84603A2	SHOES HOLDER	1
12J	84603A5	COVER	1
12K	9220	BOLT	3
	9022	SPRING WASHER	3
	9330	WASHER	3

**DECLARATION OF CONFORMITY / CERTIFICAT DE CONFORMITE /
GELIJKVORMIGHHEIDSCERTIFICAAT / DECLARACION DE CONFORMIDAD /
DECLARACAO DE CONCORMIDADE / DICHIARAZIONE DI CONFORMITA**

Model : BT120-2-5-PFV35.1

We Beton Trowel NV

Declare under our sole responsibility that the product to which this declaration relates is in conformity with the following standards or other normative documents.

Declarons sous notre responsabilite que le produit cette declaration est conforme aux norms suivantes ou d'autres documents habituels.

Verklaren onder onze verantwoordelijkheid dat het product naar welke de verklaring verwijst conform de volgende standards of anders gebruikelijke documenten is.

Declaramos bajo nuestra unica responsabilidad que el producto en lo que esta declaracion concierne, es conforme con la siguiente normative u otros documentos.

Declara sob sua responsabilidade que o produto a quem esta declaracao interessar, esta em conformidade com os seguintes documentos legais ou normas directivas.

Dichiariamo sotto la ns. Unica responsibilita che il prodotto al quale questa dichiarazione si riferisce, e fabbricato in conformita ai seguenti standard e documenti di normative.

EN 349:2008+A1:2008 EN 12100:2010 EN12649:2008+A1:2011 EN ISO 5349-2:2001 +A1:2015

Following the provisions of Directives:

Suivant les directives determinees:

Volgens de vastgestelde richtlijnen:

Siguiendo las directivas:

No sequimento das clausulas da Directivas

Seguendo quanto indicato dalla Direttivas:

2006/42/EC Machinery Directive

2000/14/EC Noise Directive

2001/95/EC General Product Safety Directive

2002/95/EC Reduction of Hazardous Waste Directive

LVD2014/35/EU Low Voltage Directive

2004/30/EU Electromagnetic Compatibility



Responsible Technical File : Chris Livingston for

Beton Trowel NV

Nijverheidsstraat 10

B-1840 Londerzeel

Belgium

Tel 0032 52315350

Fax0032 52303739

25th August 2016