

POWER TROWEL BT120H270 – BT120H340 – BT120H390





Beton Trowel nv

Use this guide along with the parts lists attached to locate and identify components of your trowel. When ordering replacement parts, be sure to provide the model number and serial number from the trowel.

Copyright

© Copyright 2011 by Beton Trowel.

Contact

BETON TROWEL
Nijverheidsstraat 10
1840 Londerzeel
BELGIUM
www.betontrowel.com

Nijverheidsstraat 10
1840 Londerzeel/Belgium
Tel: +32 (0)52 315 350 - Tel: +32 (0)52 315 351
Fax: +32 (0)52 315 359
E-mail: info@betontrowel.com
BE 0821.249.312
www.betontrowel.com

BNP FORTIS: BE81 0015 9813 5624 - GEBABEBB
ING: BE BBRUBEBB



Foreword

Quality assurance / machine break in

The machine is the product of extensive engineering development designed to give long life and unmatched performance. The trowels are shipped fully assembled, and only require filling with fuel and a brief check of lubricant levels in preparation for operation.

You can help ensure that your trowel will perform at top levels by observing a simple routing on first use. Consider that your new trowel is like a new car. Just as you would break in a new car to the road or any new machine to the job, you should start gradually and build up to full use. Learn what your machine can do and how it will respond. Refer to the engine manufacturer's manual for run-in times. Full throttle and control may be used after this time period, as allowed by material. This will serve to further break in the machine on your specific application, as well as provide you with additional practice using the machine.

We thank you for the confidence you have placed in us by purchasing a Beton Trowel machine and wish you many years of satisfied use.

Table of contents

Foreword

Operation

- 1 Use
- 2 Safety precautions
- 3 ASSEMBLY INSTRUCTIONS
- 4 OPERATION (Floating)
- 5 OPERATION (Finishing)
- 6 STARTING PROCEDURE: *WARM CLIMATE
- 7 STARTING PROCEDURE: *COLD CLIMATE
- 8 STOPPING PROCEDURE
- 9 TRANSPORTING
- 10 Lubrication
- 11 Storage

Maintenance

- 1 Preventative maintenance and routine service plan
- 2 Maintenance plan
- 3 Service

Labels

Specifications

- 1 Technical data sheet
- 2 Parts

Operation

1 Use

The trowel has been developed to float and finish the edges of concrete floors, up to perimeter walls, around columns and small areas, eliminating tiring hand troweling and increasing overall productivity and quality.

2 Safety precautions

- ❖ Always keep unauthorized, inexperienced, untrained people away from this machine.
- ❖ Rotating and moving parts will cause injury if contacted. Make sure guards are in place. Keep hands and feet away from moving parts.
- ❖ Fuel the machine only when the engine is stopped, using all necessary safety precautions.
- ❖ The engine must always be stopped before attempting any repair or adjustments. Ignition switch should be off.
- ❖ To avoid slipping and loss of control when starting the trowel, the operator should maintain good footing. It is recommended that the operator wear safety shoes for added protection.
- ❖ Be careful when working around pipes or ducts protruding from the floor or slab edges. If the trowel blades hit such obstacles, damage to the machine or possible operator injury may result.
- ❖ When starting the machine, do not exceed 1/3 throttle position. A higher setting may cause the centrifugal clutch to engage and the handle to rotate.
- ❖ Be careful not to come in contact with the muffler when the engine is hot, serious burns may result!
- ❖ Over time, the blades will form a sharp edge. Be careful when handling the old blades.



Never operate the machine in an explosive atmosphere, near combustible materials or where ventilation does not clear exhaust fumes. Repair fuel leaks immediately. Refer to your engine owner's manual for more safety instructions.

3 ASSEMBLY INSTRUCTIONS

Your new trowel has been shipped to you fully assembled. All you need to do is unfold the handle and fasten the knob. Remove any shipping or packing materials. Be sure to remove and discard the band securing the safety/stop switch to the left handle. This serves only to facilitate shipping and is not intended to be a permanent feature. When removing the machine from the carton, be careful to use the handles to lift the unit from the carton. NEVER LIFT THE MACHINE BY THE RING OR DISC. Filling the fuel tank and a brief check of lubricant levels in preparation for operation is required.



IMPORTANT:

Before running machine with belt installed, ensure that engine idles properly and that the safety-switch shuts off the engine.



ATTENTION:

For any information regarding engine adjustments, please refer to the engine manual supplied.

4 OPERATION (Floating)

When the slab has set sufficiently firm that the operator's footprint leaves a very slight depression on the surface of the slab, it is ready for the floating operation. Guiding the machine on the slab is very simple, a slight upward lift of the handle causes the machine to travel to the left. Holding the handle in the neutral position, will slowly cause the machine to spin in one spot. Slight downward pressure on the handle causes the machine to travel to the right. Best results are obtained by covering approximately 4" on each turn. In other words, let the machine move right or left, backwards or forwards, approximately 4" with each revolution of the trowels. To fill a hole or cut down a hump, move the unit back and forth over the problem area.

Under normal operating conditions the machine should cover as much as 1000 sq. ft. in about 15 minutes. It is recommended that a slight tension on the trowel control cable, (but *not* a definite tilt), during the floating operation will cause the machine to operate much smoother. After the floated slab has set sufficiently, it is ready for the finishing operation.



CAUTION:

Do not let the machine stand in one spot on the soft cement. Lift from the slab when the floating operation is complete.

5 OPERATION (Finishing)

When starting the finishing operation, never set the trowels up over 1/4" pitch. After the floating operation, the first thing to do is to remove the floating disc from the blades. Clean the blades, spider plate and disc from cement paste collected during the floating operation. Increase the blade pitch up to a maximum of 1 cm for the first finishing operation and then continue to increase the pitch on the following finishing operations. Continue the finishing passes until you obtain the desired floor finish. The time required between each finishing pass is again dependent on the weather conditions and water content of the concrete etc. If some areas of the concrete set/harden too fast you may apply a small amount of water using a hand brush as an aid to achieving the finish.

6 STARTING PROCEDURE: *WARM CLIMATE

Open fuel valve on gas tank. Set throttle lever to "Fast" idle position, set choke to closed position, start engine. Open choke slightly to prevent flooding. Move to "Open" or "Run" position when engine is warm, increase throttle to maximum operation position (3600 rpm).

7 STARTING PROCEDURE: *COLD CLIMATE

Follow same procedure as above but allow longer warm-up period – 3 to 5 minutes. In cold weather, oil is much heavier to move and requires more time to work its way into the moving parts. If maximum power is not attained, allow further warm-up time.

8 STOPPING PROCEDURE

- ❖ Throttle engine down.
- ❖ Turn off stop switch.

9 TRANSPORTING

When transporting the trowel, always keep the handle folded and the blades flat on the floor to prevent damage to the pitch control system. Always keep the floating disc underneath the blades to protect them against damage.



CAUTION:

Never lift the trowel by the rotating ring; use the hoist hook or handle provided on the trowel. Remove the float disc when lifting machine more than 100cm (40in). The floating disc could fall off.

10 Lubrication

- ❖ **ENGINE OIL:** The long life and successful operation of any piece of machinery is dependent on frequent and thorough lubrication. Before using the trowel, always check your engine for oil. Use proper engine oil as recommended in the engine manufacturer's manual. Fill crankcase to levels as recommended.
- ❖ **SPIDER PLATE :** The trowel arm on the spider plate does not require lubrication. If a trowel arm becomes jammed, this is probably due to a bent arm, which will require replacement. Appropriate "winterize" steps should be taken if the machine is going to be stored for long periods of time.
- ❖ **GEARBOX:** In operation the gearbox lubricant is in a fluid state. When the machine is stopped the lubricant returns to a gel state. It will only be necessary to inspect the sealed components if the outside of the gearbox gets too oily or otherwise shows evidence of a leak. If this happens, clean the machine thoroughly and look for leaks. Effect necessary repairs immediately. Use SHELL TIVELA COMPOUNDS 'A' (0.3L, 10.1oz.) gear oil or equivalent to top up the gear box after any maintenance to the internal components.

11 Storage

The following steps should be taken to prepare your trowel for extended storage.

- ❖ Close fuel shut off valve.
- ❖ Siphon excess gasoline from tank.
- ❖ Start engine until it stops from lack of fuel. This will use up all the fuel in the carburetor and prevent formation of deposits due to evaporation of fuel.
- ❖ Remove spark plug and pour 2 oz. of SAE-30 or SAE-40 motor oil into the cylinder. Slowly crank the engine 2 or 3 times to distribute the oil throughout the cylinder. This will help prevent rust during storage. Replace spark plug.
- ❖ Store the unit in an upright position in a cool, dry, well ventilated area.

Maintenance

1 Preventative maintenance and routine service plan.

This trowel has been assembled with care and will provide years of service. Preventative maintenance and routine service are essential to the long life of your trowel. Your dealer is interested in your new machine and has the desire to help you get the most value from it. After reading through this manual thoroughly, you will find that you can do some of the regular maintenance yourself. However, when in need of parts or major service, be sure to see Beton Trowel.

- ❖ **AIR CLEANER** - Keep air filter clean at all times. Wash away dust and debris using a non-oil based cleaning solvent. Let the filter dry before re-installing.
- ❖ **LUBRICATION** – Always check engine oil regularly. Use proper engine oil as recommended. See chart on this page. Fill crankcase to levels as recommended in manufacture’s engine manual.
- ❖ **SPARK PLUG** – Check and clean spark plugs regularly. A fouled, dirty or carboned spark plug causes hard starting and poor engine performance. Set spark plug gap to recommended clearance. Refer to engine manual.
- ❖ **BELT TENSION – IMPORTANT!**

When the engine is switched off, and the machine has stopped, the normal belt play should be loose. This is due to the clutch type. When the machine is running at full throttle, the clutch will close in, which tightens the belt causing the gearbox to engage.

When adjusting the belt make sure that the clutch is in alignment with the follower pulley. Secure belt guard. Tighten all engine mount bolts, and tighten lock nuts.

2 Maintenance plan

Routine Service Intervals		Each use	After 1.5 months or 50 hrs	Each 3 months or 100 hrs	Each 6 months or 200 hrs	Each 9 months or 300 hrs	Each 12 months or 400 hrs
General Inspection:							
Guards	Check		o	o	o	o	o
Warning stickers	Check		o	o	o	o	o
Test run	Check operation		o	o	o	o	o
Controls:							
Dead-man switch operation	Check	o	o	o	o	o	o
Pitch control assembly	Check	o	o	o	o	o	o
	Lubricate		o	o	o	o	o
Engine:							
Engine oil	Check Level	o	o	o	o	o	o
	Change		o		o		o
Engine oil filter	Replace				o		o
Oil cooler	Clean			o	o	o	o
Cooling Fins	Clean		o	o	o	o	o
Air cleaner	Check - clean	o	o	o	o	o	o
	Replace						o
Air Intake Line	Check				o		
	Replace						2 yrs
Fan Belt	Check tightness				o		o
	Replace						500 hrs
Valve clearance	Check-adjust				o		o
Fuel filter	Check & Clean			o	o	o	o
	Replace				o		o
Fuel Tank	Clean						500 hrs
Engine wiring	Check						o
Drive Train:							
Clutch / Pulley operation	Check	o	o	o	o	o	o
Spider plate assembly	Check	o	o	o	o	o	o
	Lubricate				o		o
V-Belt	Check	o	o	o	o	o	o
Blades	Check	o	o	o	o	o	o
Gearbox:							
Gearbox oil	Check Level				o		o
	Change	o			o		o
Gearbox breathers	Check operation			o	o	o	o

3 Service

Due to the nature and environment of use, the machines could be exposed to severe operating conditions. Some general maintenance guidelines will extend the useful life of your trowel.

- ❖ The initial service for your trowel should be performed after 25 hours of use, at which time your mechanic (or authorized repair shop) should complete all of the recommended checks in the schedule above.
- ❖ Regular service according to the schedule above will prolong the life of the trowel and prevent expensive repairs.
- ❖ Keeping your trowel clean and free from debris is the single most important regular maintenance operation, over and above the checks in the service schedule above, that can be performed. After each use your trowel should be cleaned to remove any dust and debris from the undercarriage and surrounding components. Use of a power washer will make clean up quick and easy, especially if a non-stick coating was applied prior to use.
- ❖ In the Service Schedule above, items that should be checked, replaced or adjusted are indicated by “o” in the appropriate column. Not all trowel models include the same features and options and as such not all service operations may have to be performed. For ease of recording place a checkmark (✓) through the “o” when the item is complete. If an item is not required or not completed place an “x” through the “o” in the box.

Labels

SAFETY PRECAUTIONS	
	<p>! DANGER</p> <p>EXPLOSION HAZARD Never operate the machine in an explosive atmosphere, near combustible materials or where ventilation does not clear exhaust fumes.</p>
	<p>WARNING</p> <p>BURN HAZARD Never come into contact with the engine or muffler when engine is operating or shortly after it is turned off. Serious burns may occur.</p>
	<p>! CAUTION</p> <p>ROTATING HAZARD Never place hands or feet inside safety guard rings. Serious injury will result from contact with rotating blades.</p>
	<p>! CAUTION</p> <p>MOVING PARTS Before starting the machine ensure that all guards and safety devices are in place and functioning properly.</p>
	<p>! ATTENTION</p> <p>READ OWNERS MANUAL Read and understand operator's manual before using this machine. Failure to follow operating instructions could result in serious injury or death.</p>

Specifications

1 Technical data sheet

MODEL	BT120H270	BT120H340	BT120H390
OPERATING DIAMETER	120 CM (46")	120 CM (46")	120 CM (46")
ENGINE OPTIONS	HONDA GX270 9 HP	HONDA GX340 11 HP	HONDA GX390 13 HP
HANDLE TYPE	RIGID TRI-TUBE DUAL SAFETY	RIGID TRI-TUBE DUAL SAFETY	RIGID TRI-TUBE DUAL SAFETY
WEIGHT	110 KG	113 KG	114 KG
HANDLE VIBRATION	1.1 – 1.5 M/S	1.1 – 1.5 M/S	1.1 – 1.5 M/S
SOUND	97 – 103 LWA (dB) 82 -86 LPA (Db)	97 – 103 LWA (dB) 82 -86 LPA (Db)	97 – 103 LWA (dB) 82 -86 LPA (Db)

2 Parts

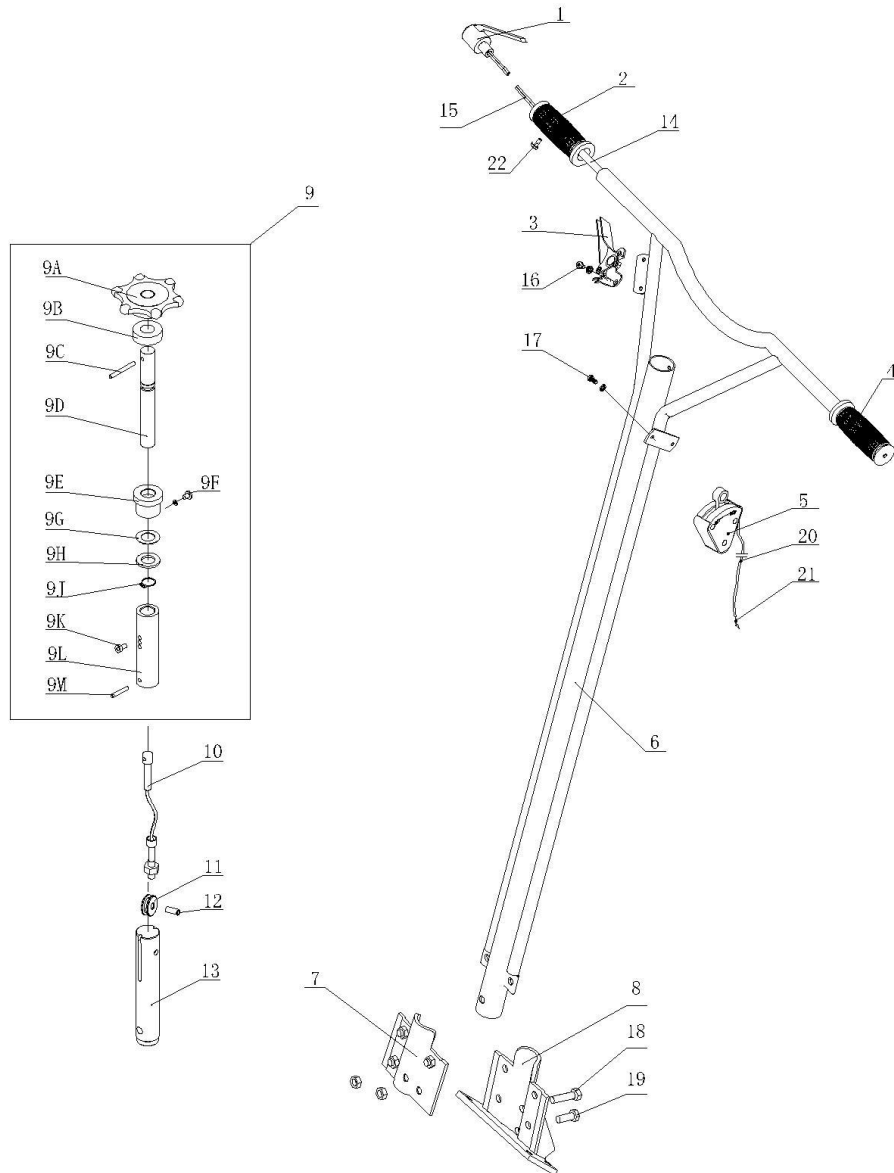

Item No.	Part No.	Description	Qty.
	4465000	WHOLE HANDLE ASSY	
1	1165200A	DEADMAN SWITCH	1
2	9035a	GRIP	1
3	4365400	THROTTLE CONTROL	1
4	9035	GRIP	1
5	4365200	SAFETY SWITCH	1
6	4465100	BARE HANDLE	1
7	4465301	UPPER BRACKET	1
8	4465300	LOWER BRACKET	1
9	4465500	KNOB ASSY	1
9A	4365501	KNOB	1
9B	9025	BEARING	1
9C	9024	PIN	1
9D	4365503	THREADED SHAFT	1
9E	4465502	BUSHING	1
9F	9026	SCREW	1
	9022	SPRING WASHER	1
9G	9033	SPRING WASHER	1
9H	4365504	WASHER	2
9J	9027	RETAINER	1
9K	9028	SCREW	1
9L	4465505	ALUMINIUM BUSHING	1
9M	9157A	PIN	1
10	4465512	PITCH CONTROL CABLE	1
11	4365508	CABLE WHEEL	1
12	9158A	PIN	1
13	4465511	CABLE WHEEL BUSHING	1
14	9126	SLEEVE	1
15	4465520	WIRE	2
16	9021	SCREW	2
	9011	WASHER	2
17	9010	SCREW	2
	9011	WASHER	2
18	9165	BOLT	1
	9016	NUT	1



Beton Trowel nv

19	9018	BOLT	4
	9016	NUT	4
20	9008	SLEEVE	1
21	9009	WIRE	1
	9007	CONNECTOR	1
	9012	CONNECTOR	1
22	9021	SCREW	1
	9128	SPRING WASHER	1

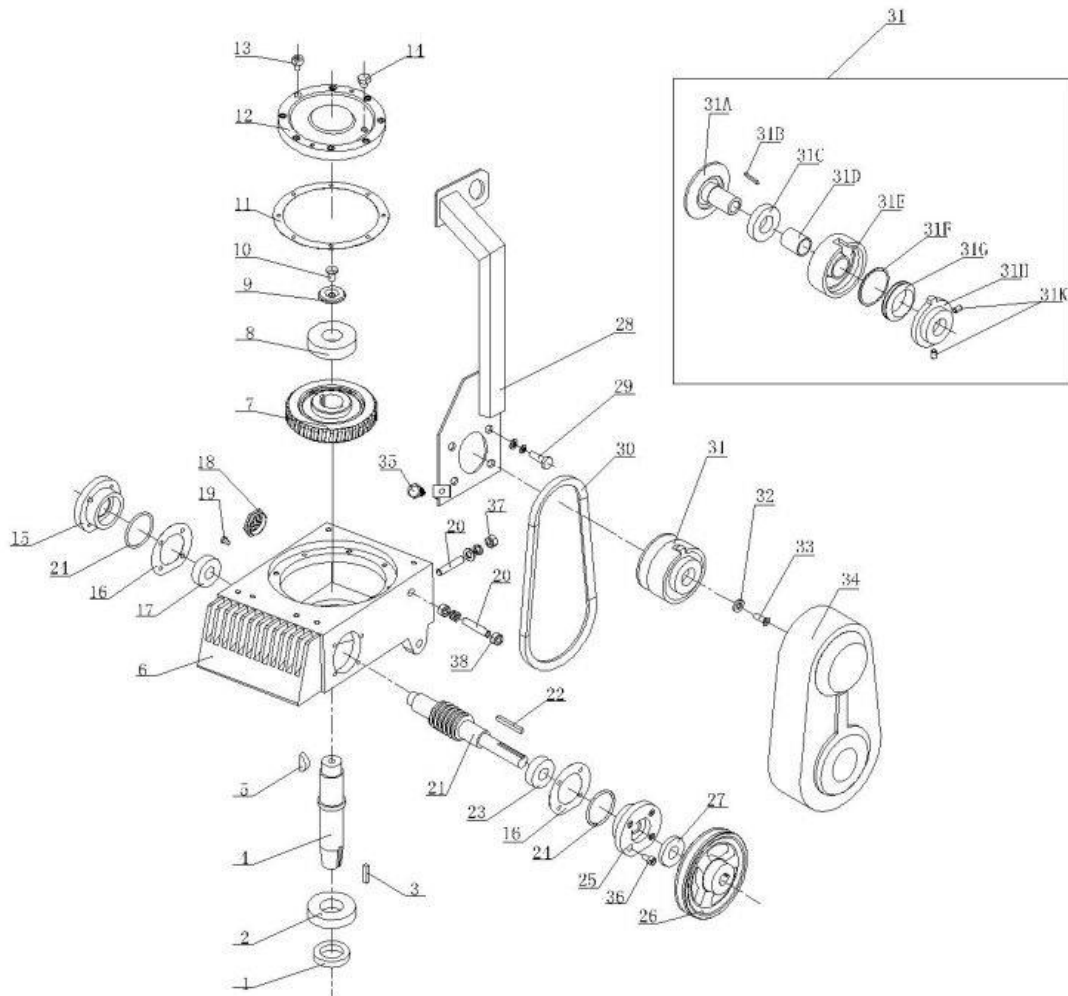

Item No.	Part No.	Description	Qty.
1	9153	SEAL	1
2	9222A	BEARING	1
3	9154	KEY	1
4	4464011	MAIN SHAFT	1
5	9156	KEY	1
6	4464003	GEARBOX CASING	1
7	4464010	WORM GEAR	1
8	9144	BEARING	1
9	4364006	WASHER	1
10	4364007	BOLT	1
11	4464008	PLASTIC SHIMMING	1
12	4464005	GEARBOX COVER	1
13	9118	SCREW	8
14	4364100	RELEASE VALVE	1
15	4464014	BEARING FLANGE	1
16	4464015	PLASTIC SHIMMING	1
17	9141	BEARING	1
18	9064	SIGHT GLASS	1
19	9053	BOLT	2
20	9044	BOLT	5
	9046	SPRING WASHER	5
	9047	WASHER	5
21	4464013	COUNTER SHAFT	1
22	9054	KEY	1
23	9143	BEARING	1
24	9152	SEAL	2
25	4464012	BEARING FLANGE	1
26	4462001	PULLEY	1
27	9055	SEAL	1
28	4468000	HOOK LIFT	1
29	9151	BOLT	4
	9037	SPRING WASHER	4
	9038	WASHER	4
30	9160	BELT	1
31	4463000	CLUTCH	1

31A	4463001	SPINDLE	1
31B	9155	KEY	1
31C	9142	BEARING	1
31D	4463006	BUSHING	1
31E	4463002	DRUM	1
31F	9335	SPRING	1
31G	4463004	WEIGHT	1
31H	4463003	FACE PLATE	1
31K	9062	BOLT	1
	9748	BOLT	1
32	4363005	WASHER	1
33	9146	SCREW	1
34	4462100	BELT GUARD(9HP)	1
	4462100A	BELT GUARD(13HP)	1
35	9097	BOLT	1
	9037	SPRING WASHER	1
	9038	WASHER	1
36	9043	SCREW	12
37	9045	NUT	4
38	9091	NUT	2

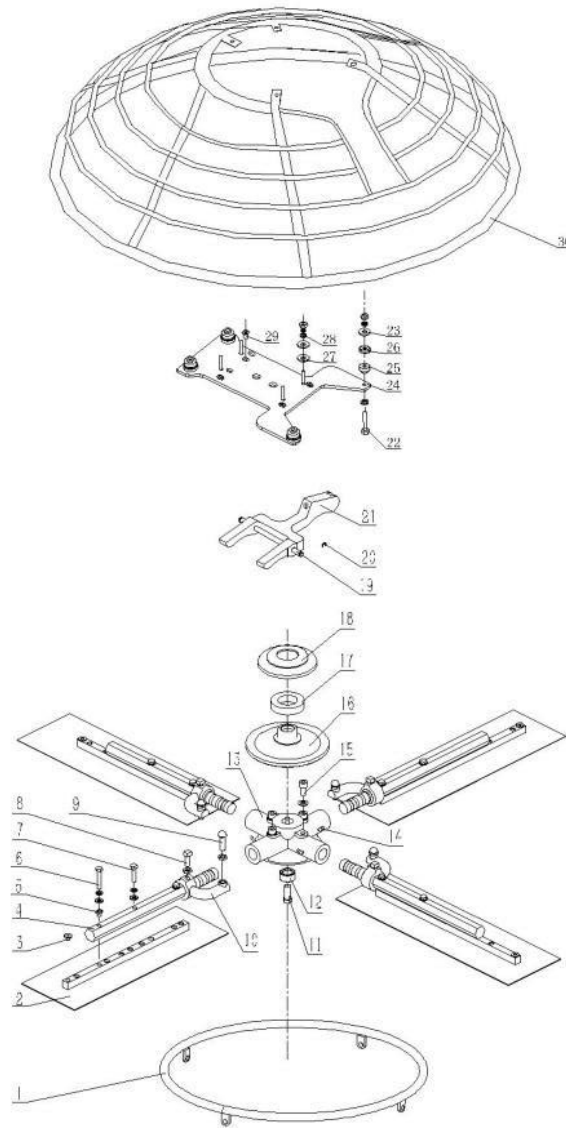



Beton Trowel nv

Item No.	Part No.	Description	Qty.
1	4466103I	STABILIZER RING	1
2	F120416	BLADE	4
3	4366911	BLOCK	4
4	4466001	TROWEL ARM	4
5	4366007a	ADJUSTING NUT	4
6	9215	BOLT	4
	9037	SPRING WASHER	4
	9038	WASHER	4
7	9040	BOLT	8
	9037	SPRING WASHER	8
	9038	WASHER	8
8	9065	BOLT	4
9	9067	BOLT	4
10	4466006	LIFTING LEVER	4
11	9068	BOLT	1
12	4466004	BUSHING	1
13	4466005	SPIDER PLATE	1
14	9069B	NIPPLE	4
15	9066	BOLT	4
	9046	SPRING WASHER	4
16	4466003	PRESSURE PLATE	1
17	9140	BEARING	1
18	4466002	PRESSURE PLATE COVER	1
19	4465509	SHAFT	1
20	9202	RETAINER	1
21	4465510	YOKE ARM	1
22	9040	BOLT	4
	9037	SPRING WASHER	4
	9038	WASHER	4
	9036	NUT	4
23	9039	WASHER	4
24	4467030	ENGINE DECK(9HP)	1
	4467020	ENGINE DECK(13HP)	1
25	4364009	RUBBER CUSHION	4
26	4364002	CUSHION COVER	4

Nijverheidsstraat 10
 1840 Londerzeel/Belgium
 Tel: +32 (0)52 315 350 - Tel: +32 (0)52 315 351
 Fax: +32 (0)52 315 359
 E-mail: info@betontrowel.com
 BE 0821.249.312
 www.betontrowel.com

BNP FORTIS: BE81 0015 9813 5624 - GEBABEBB
 ING: BE BBRUBEBB



Beton Trowel nv

27	9159	WASHER	8
28	9046	SPRING WASHER	4
	9047	WASHER	4
	9091	NUT	4
29	9145	SCREW	6
30	2467000	GUARD RING	1

Declaration of Conformity / Certificat de conformite / Gelijkvormigheidscertificaat / Declaracion de Conformidad / Declaracao de Concormidade / Dichiarazione Di Conformita

Model : BT120

We Beton Trowel NV

Declare under our sole responsibility that the product to which this declaration relates is in conformity with the following standards or other normative documents.

Declarons sous notre responsabilite que le produit cette declaration est conforme aux norms suivantes ou d'autres documents habituels.

Verklaren onder onze verantwoordelijkheid dat het product naar welke de verklaring verwijst conform de volgende standards of anders gebruikelijke documenten is.

Declaramos bajo nuestra unica responsabilidad que el producto en lo que esta declaracion concierne, es conforme con la siguiente normative u otros documentos.

Declara sob sua responsabilidade que o produto a quem esta declaracao interessar, esta em conformidade com os seguintes documentos legais ou normas directivas.

Dichiariamo sotto la ns. Unica responsibilita che il prodotto al quale questa dichiarazione si riferisce, e fabbricato in conformita ai seguenti standard e documenti di normative.

EN 349:2008+A1:2008 EN 12100:2010 EN12649:2008+A1:2011 EN ISO 5349-2:2001 +A1:2015

Following the provisions of Directives:

Suivant les directives determinees:

Volgens de vastgestelde richtlijnen:

Siguiendo las directivas:

No sequimento das clausulas da Directivas

Seguendo quanto indicato dalla Direttivas:

2006/42/EC Machinery Directive

2000/14/EC Noise Directive

2001/95/EC General Product Safety Directive

2002/95/EC Reduction of Hazardous Waste Directive

LVD2014/35/EU Low Voltage Directive

2004/30/EU Electromagnetic Compatibility

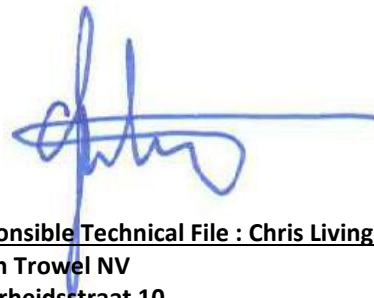

Responsible Technical File : Chris Livingston for

Beton Trowel NV

Nijverheidsstraat 10

B-1840 Londerzeel

Belgium

Tel 0032 52315350

Fax0032 52315359

25th August 2016