

## INSTRUCTION MANUEL

### PORTABLE VIBRATOR BT-45H





# Beton Trowel nv

---

Use this guide along with the parts lists attached to locate and identify components of your trowel. When ordering replacement parts, be sure to provide the model number and serial number from the trowel.

## Copyright

© Copyright 2011 by Beton Trowel.

## Contact

BETON TROWEL  
Nijverheidsstraat 10  
1840 Londerzeel  
BELGIUM  
[www.betontrowel.com](http://www.betontrowel.com)

---

Nijverheidsstraat 10  
1840 Londerzeel/Belgium  
Tel: +32 (0)52 315 350 - Tel: +32 (0)52 315 351  
Fax: +32 (0)52 315 359  
E-mail: [info@betontrowel.com](mailto:info@betontrowel.com)  
BE 0821.249.312  
[www.betontrowel.com](http://www.betontrowel.com)

BNP FORTIS: BE81 0015 9813 5624 - GEBABEBB  
ING: BE BBRUBEBB



## Foreword

### **General Safety Instructions for the Operation of Power Equipment**

The goal is to produce power equipment that helps the operator work safely and efficiently. The most important safety device for this or any tool is the operator. Care and good judgment are the best protection against injury. All possible hazards cannot be covered here, but we have tried to highlight some of the important items. Individuals should look for and obey Caution, Warning and Danger signs placed on equipment, and displayed in the workplace. Operators should read and follow safety instructions packed with each product.

Learn how each machine works. Even if you have previously used similar machines, carefully check out each machine before you use it. Get the "feel" of it and know its capabilities, limitations, potential hazards, how it operates and how it stops.

We thank you for the confidence you have placed in us by purchasing a Beton Trowel machine and wish you many years of satisfied use.

## Table of contents

<b>Foreword</b>	<b>3</b>
<b>1 Applications</b>	<b>5</b>
<b>2 Safety precautions</b>	<b>5</b>
<b>3 Assembly</b>	<b>7</b>
<b>4 Functions and Risks</b>	<b>8</b>
<b>5 Operation</b>	<b>9</b>
<b>6 Maintenance</b>	<b>10</b>
1 Maintenance plan	10
2 Care and preventive maintenance	10
3 Cleaning and storage	11
<b>7 Labels</b>	<b>12</b>
<b>8 Parts List</b>	<b>13</b>

## 1 Applications

- Civil : roadways, kerbing, pre cast beams, bridge decks, piers.
- Commercial buildings : strip and raft foundations, stairs, walls, floors, driveways, suspended slabs, tilt panels, stack cast panels.
- Residential building : floor slumps, wall cavities, house slabs, wall footings, paving slabs.
- Rural : fence posts, stock troughs and pens

## 2 Safety precautions

- NEVER allow any person to operate equipment without adequate instruction.
- ENSURE all operators read, understand and follow the operating instructions.
- SEIOUS INJURY may result from improper or careless use of this machine.
- Mechanical hazards:
  - DO NOT operate the machine unless all protective guards are in place.
  - ENSURE that the motor operation switch is in the OFF position and the spark plug ignition lead is disconnected before removing the guards or making adjustments.
  - KEEP hands and feet clear of rotating and moving parts as they will cause injury if contacted.
  - DO NOT leave the equipment in operation while it is unattended.
  - EXERCISE CARE when handling vibrators. Exposure to vibration or repetitive work actions may be harmful to hands and arms.
  - DO NOT hold the vibrator shaft in your hands while it is running. Hold the vibrator by the "D" handle & use the supplied carry strap to help isolate your hands from the vibration.
  - NEVER stand on the vibrating head while it is operating.
  - DO NOT place your foot on the vibrator head while it is running unless it is done momentarily and the vibrator head is resting on a resilient support such as a car type.
  - BE CAREFUL not to come in contact with the muffler when the engine is hot, since it can cause severe burns.
  - ENSURE that repairs to machinery are carried out by COMPETENT personnel.

## Fire & Explosion hazards:

- PETROL is extremely flammable and explosive under certain conditions.
- ENSURE that petrol is only stored in an approved storage container.
- DO NOT refuel the motor while it is in operation or hot.
- DO NOT refuel the motor in the vicinity of sparks, a naked flame or a person smoking.
- DO NOT over fill the fuel tank and avoid spilling petrol when refueling. Spilled petrol or petrol vapour may ignite. If spillage occurs, ensure that the area is dry before starting the motor.
- Motor vibrations can cause an improperly tightened fuel cap to loosen or come off and spill quantities of fuel. In order to reduce risk of fuel spillage and fire, tighten fuel cap by hand with as much force as possible.
- To reduce the risk of serious injury from burns, never attempt to refuel the unit until it has been stopped & completely removed from the operator.

## Chemical hazards:

- DO NOT operate or refuel a petrol motor in a confined area without adequate ventilation.
- CARBON MONOXIDE exhaust gases from internal combustion motor driven units can cause death in confined spaces.

## Noise hazards:

- EXCESSIVE NOISE can lead to temporary or permanent loss of hearing.
- WEAR an approved hearing protection device to limit noise exposure. As required by Occupational Health and Safety regulations. Noise levels in excess of 85dB(A) may be produced by engines and vibrators.

## Protective clothing





- ALWAYS wear protective clothing and footwear to prevent the skin coming into contact with wet concrete.
- PROTECTIVE FOOTWEAR should be worn to reduce injuries from penetration through the sole, contact with cutting objects, slipping, contact with wet concrete and electrical hazards.
- GOGGLES for eye protection may also be necessary.
- USE waterproof protection for hands and knees (if kneeling) when concreting. If your clothing becomes wet from concrete contact make sure you change the clothing. Do not walk about waiting for it to dry.
- USE GLOVES when handling and inspecting the flexible shaft outer casing. Excessive wear of the rubber cover can expose the wire braided reinforcement, allowing it to project and cause injury.

## Additional hazards

- To reduce the risk of injury from loss of balance, start the motor with the unit on a flat level surface, and only pick up the unit when the engine is idling.
- Slip/Trip/Fall is a major cause of serious injury or death. Beware of the flexible shaft and water left on the walking or work surface.
- Exercise caution and ensure that the perimeter of elevated formwork or platforms is protected.
- Exercise care when working in the vicinity of unprotected holes or excavations.

## 3 Assembly

If the unit was supplied unassembled the following must be completed prior to operation:

-  The unit is supplied with the flexible shaft disconnected from the motor unit. To attach the flexible shaft, place the threaded ferrule end of the flexible shaft approximately 20mm from the coupling housing. Engage the squared end of the flexible shaft core assembly into the squared seal sleeve adaptor.
-  The threaded ferrule end of the flexible shaft may now be screwed into the motor adaptor. Rotate the ferrule end of the flexible shaft in an anti-clockwise direction to engage the left hand thread. Once tightened by hand use multigrip pliers to ensure the ferrule is tightened sufficiently to stop it from working loose and coming detached during operation.
-  A 1 liter container of Honda 10W/30 engine oil is included with the unit. Engine oil capacity is 100ml. To add oil place the unit on a level surface and remove the oil filler cap. Add oil until the oil level reaches the edge of the oil filler neck & reinstall the oil filler cap.
-  Fuel may now be added and the unit is ready for operation.

## 4 Functions and Risks

### Drive Unit

This portable drive unit is designed to power flexshaft drive, eccentric vibrators. The motor is controlled by an ON/OFF push button which is mounted below the throttle lever on the handle.

The motor speed is controlled by throttle lever mounted on the handle.

A centrifugal clutch is fitted to the motor which disengages the drive to the vibrator when the motor is idling.

The clutch operates automatically and requires no adjustment.

The motor is a 4-stroke unit and must only be used with unleaded petrol.

### Vibrator

This vibrator is designed for the compaction of concrete by immersion of the vibrator head. Compaction improves the strength and finish of concrete by driving out entrapped air. High frequency vibration allows the efficient compaction of low slump concrete mixes.

The vibrator head is driven by a rotating flexible drive shaft that transmits the drive from the drive unit.

The vibrator head uses an eccentric mass to produce vibration. Ball bearings support the rotor at each end.



## 5 Operation

- ☛ To start the motor, place the unit on a flat level surface, and only pick up the unit when the engine is idling.
  - ☛ To start the motor turn the engine switch to the ON position.
  - ☛ To start a cold engine, move the choke lever to the closed position.
  - ☛ To restart a warm engine, leave the choke lever in the OPEN position.
  - ☛ Press the priming pump several times until a flow in the fuel return tube is visually noticed.
  - ☛ Pull the starter grip lightly until you feel resistance while holding the unit steady; then pull briskly. Return the starter grip gently.
  - ☛ If the choke lever is in the CLOSED position, gradually move it to the OPEN position as the engine warms up.
  - ☛ The idle-up function helps the engine start by opening the throttle valve in the carburetor moderately when the engine won't start.
1. Hold down the throttle interlock.
  2. Pull the throttle trigger.
  3. Push the idle-knob, then release the throttle trigger and the interlock.
  4. Start the engine
- NOTE: This function must not be used when vibrating.

Always operate the unit at full throttle. This will ensure correct concrete compaction and avoid damage to the drive mechanism.

Be careful starting and or revving the unit on loose gravel as it may be sucked into the flywheel cooling fins causing damage to the unit.

Avoid sharp bends in the flexshaft, particularly when it is in use.

Do not use an eccentric-type immersion vibrator head as an external vibrator by applying it to the outside of formwork.

Do not operate the vibrating head out of concrete for extended periods. Do not leave it running while you wait for fresh supplies of concrete to be placed. Vibrator heads are designed to be cooled by the concrete in which they are immersed.

## 6 Maintenance

### 1 Maintenance plan

<b>Routine Service Intervals</b>		Each use	After 1.5 months or 50 hrs	Each 3 months or 100 hrs	Each 6 months or 200 hrs	Each 9 months or 300 hrs	Each 12 months or 400 hrs
<b>General Inspection:</b>							
Rubber Cap	Check		o	o	o	o	o
Warning stickers	Check		o	o	o	o	o
Test run:	Check operation		o	o	o	o	o
<b>Engine:</b>							
Engine oil	Check Level	o	o	o	o	o	o
	Change		o		o		o
Engine oil filter	Replace				o		o
Oil cooler	Clean			o	o	o	o
Cooling Fins	Clean		o	o	o	o	o
Air cleaner	Check - clean	o	o	o	o	o	o
	Replace						o
Air Intake Line	Check				o		
	Replace						2 yrs
Fan Belt	Check tightness				o		o
	Replace						500 hrs
Valve clearance	Check-adjust				o		o
Fuel filter	Check & Clean			o	o	o	o
	Replace				o		o
Fuel Tank	Clean						500 hrs
Engine wiring	Check						o

### 2 Care and preventive maintenance

- ☑ Keep the unit clean and free of concrete residue.
- ☑ Check the oil level in the engine crankcase daily, it should reach the edge of the oil filler neck. The engine oil capacity is only 100 ml and running the engine with a low oil level will cause serious engine damage.
- ☑ Vibrators must be handled with care, and be properly maintained in order to avoid unnecessary breakdowns. Check regularly for signs of wear and rectify any faults immediately.
- ☑ The exterior of the flexshaft and the vibrator head are subject to abrasion and wear. If the vibrator is operated unchecked, concrete will eventually enter the vibrator head or the flexshaft. Naturally, the cost of repairing, a vibrator which has been allowed to deteriorate in this way will be greater.

- ☛ Regular inspection of the vibrator and the flexible shaft will avoid these problems.
- ☛ Check the flexible shaft for kinks and external damage by laying it out straight on a workbench or the floor. Although it still operates, a badly kinked flexible shaft may result in a broken inner core.
- ☛ Check the outer casing rubber cover for damage where it enters the ferrule at the vibrator head. Damage is caused by operators using a crane to retrieve a vibrator trapped in concrete reinforcing bars.

### 3 **Cleaning and storage**

It is advisable to wash the vibrator head and flexshaft with clean water after use each day and before storing. This will ensure that concrete does not accumulate on the exterior.

Ensure the cooling fins on the motor are kept unobstructed.

## 7 Labels

SAFETY PRECAUTIONS	
	<p><b>! DANGER</b></p> <p><b>EXPLOSION HAZARD</b> Never operate the machine in an explosive atmosphere, near combustible materials or where ventilation does not clear exhaust fumes.</p>
	<p><b>WARNING</b></p> <p><b>BURN HAZARD</b> Never come into contact with the engine or muffler when engine is operating or shortly after it is turned off. Serious burns may occur.</p>
	<p><b>! CAUTION</b></p> <p><b>ROTATING HAZARD</b> Never place hands or feet inside safety guard rings. Serious injury will result from contact with rotating blades.</p>
	<p><b>! CAUTION</b></p> <p><b>MOVING PARTS</b> Before starting the machine ensure that all guards and safety devices are in place and functioning properly.</p>
	<p><b>! ATTENTION</b></p> <p><b>READ OWNERS MANUAL</b> Read and understand operator's manual before using this machine. Failure to follow operating instructions could result in serious injury or death.</p>

## 8 Parts List

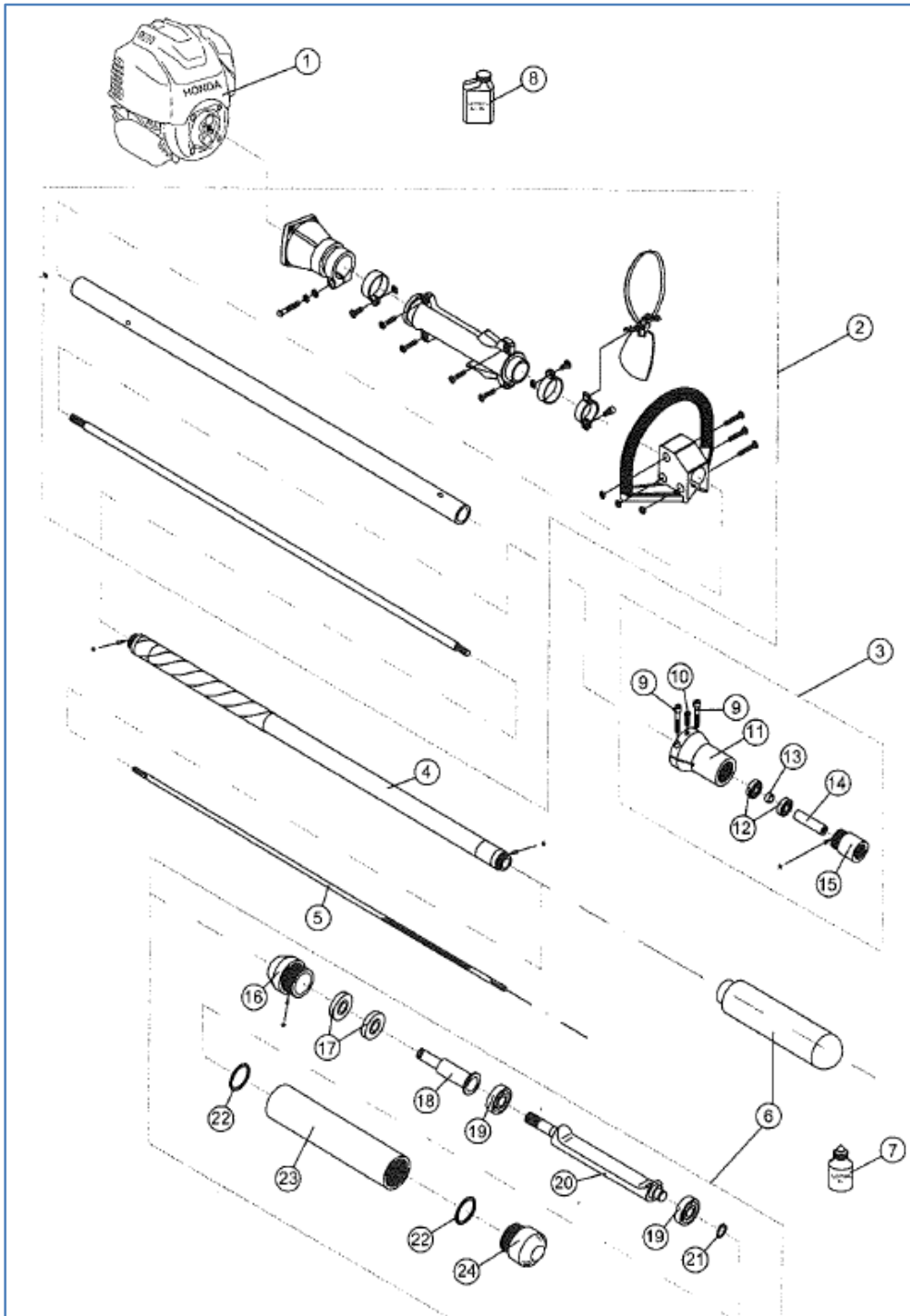

## PORTABLE VIBRATOR

ITEM	PART NO.	DESCRIPTION	QUANTITY
1	F03318	Motor – Honda GX35 (Portavibe)	1
2	F03320	Drive Shaft – Throttle Assy. – Portavibe	1
3	F03282	Coupling Assembly	1
4	F03001	Casing Assy.	1
5	F03002	Core Assy.	1
6	F09328	Vibrator Head Assy.	1
7	F06700	Oil (Vib. Head)	1
8	H1002-P08-001	Oil 10w – 30w HONDA	1
9	F05876	Screw – Socket Head Cap 1/4" BSW	2
10	F02986	Screw – Button Head Cap 1/4" BSW	1
11	F02982	Coupling Housing	1
12	F01515	Bearing	2
13	F03281	Spacer	1
14	F08870	Seal Sleeve	1
15	F05359	Motor Adaptor	1
16	F09329	Seal Housing	1
17	F07508	Oil Seal	2
18	F06609	Spindle Adaptor	1
19	F09330	Ball Bearing	2
20	F09332	Rotor	1
21	F04180	Circlip	1
22	F04850	O-Ring	2
23	F09331	Barrel	1
24	F09333	Nose Cap	1

## Declaration of Conformity / Certificat de conformite / Gelijkvormigheidscertificaat / Declaracion de Conformidad / Declaracao de Concormidade / Dichiarazione Di Conformita

Model : BT45H

We Beton Trowel NV

Declare under our sole responsibility that the product to which this declaration relates is in conformity with the following standards or other normative documents.

Declarons sous notre responsabilite que le produit cette declaration est conforme aux norms suivantes ou d'autres documents habituels.

Verklaren onder onze verantwoordelijkheid dat het product naar welke de verklaring verwijst conform de volgende standards of anders gebruikelijke documenten is.

Declaramos bajo nuestra unica responsabilidad que el producto en lo que esta declaracion concierne, es conforme con la siguiente normative u otros documentos.

Declara sob sua responsabilidade que o produto a quem esta declaracao interessar, esta em conformidade com os seguintes documentos legais ou normas directivas.

Dichiariamo sotto la ns. Unica responsibilita che il prodotto al quale questa dichiarazione si riferisce, e fabbricato in conformita ai seguenti standard e documenti di normative.

EN 349.1993    EN ISO 4872.1978    EN 12100-1.2003    EN ISO 5349-2.2001  
EN 12100-2.2003    EN 418.1993    EN ISO 5349-1.2001

Following the provisions of Directives:

Suivant les directives determinees:

Volgens de vastgestelde richtlijnen:

Siguiendo las directivas:

No sequimento das clausulas da Directivas

Seguendo quanto indicato dalla Direttivas:

**98/37/EC Machinery Directive**  
**2000/14/EC Noise Directive**  
**2001/95/EC General Product Safety Directive**  
**2002/95/EC Reduction of Hazardous Waste Directive**



**Responsible Technical File : Chris Livingston for**  
**Beton Trowel NV**  
**Nijverheidsstraat 10**  
**B-1840 Londerzeel**  
**Belgium**  
Tel 0032 52315350  
Fax0032 52303739  
25<sup>th</sup> August 2016