

INSTRUCTION MANUAL

SLAB SAW BTCS501





Beton Trowel nv

Use this guide along with the parts lists attached to locate and identify components of your saw. When ordering replacement parts, be sure to provide the model number and serial number from the trowel.

Copyright

© Copyright 2011 by Beton Trowel.

Contact

BETON TROWEL
Nijverheidsstraat 10
1840 Londerzeel
BELGIUM
www.betontrowel.com

Nijverheidsstraat 10
1840 Londerzeel/Belgium
Tel: +32 (0)52 315 350 - Tel: +32 (0)52 315 351
Fax: +32 (0)52 315 359
E-mail: info@betontrowel.com
BE 0821.249.312
www.betontrowel.com

BNP FORTIS: BE81 0015 9813 5624 - GEBABEBB
ING: BE BBRUBEBB

Foreword

Quality assurance / machine break in

The machine is the product of extensive engineering development designed to give long life and unmatched performance. The saws are shipped fully assembled, and only require filling with fuel and a brief check of lubricant levels in preparation for operation.

You can help ensure that your saw will perform at top levels by observing a simple routing on first use. Consider that your new saw is like a new car. Just as you would break in a new car to the road or any new machine to the job, you should start gradually and build up to full use. Learn what your machine can do and how it will respond. Refer to the engine manufacturer's manual for run-in times. Full throttle and control may be used after this time period, as allowed by material. This will serve to further break in the machine on your specific application, as well as provide you with additional practice using the machine.

We thank you for the confidence you have placed in us by purchasing a Beton Trowel machine and wish you many years of satisfied use.

1 Basic Safety Instructions

Uses other than the manufacturer's instructions shall be considered as contravening the regulations. The manufacturer shall not be held responsible for any resulting damage. Any risk shall be borne entirely by the user. Observing the operating instructions and compliance with inspection and servicing requirements shall also be considered as included under use in accordance with the regulations.

Important warnings and pieces of advice are indicated on the machine using symbols. The following symbols are used on the machine:

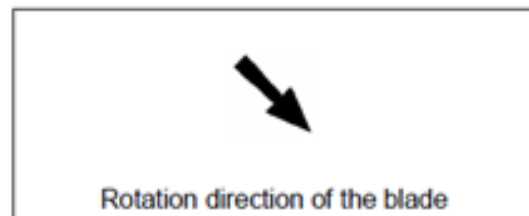
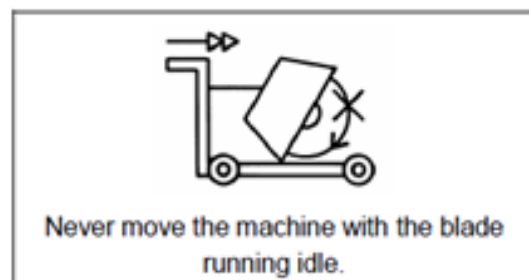
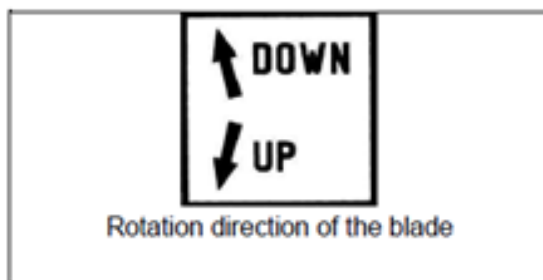

2 General description of the BTCS501

Any modification, which could lead to a change in the original characteristics of the machine, may be done only by Beton Trowel NV who shall confirm that the machine is still in conformity with the safety regulations. Beton Trowel NV keeps the right of making technical or design modification without prior notification.

2.1 Short description

The **Floor Saw BTCS501** you have chosen, is used for small repair works in concrete and asphalt, for cutting induction loops and installing cables as well as for cutting expansion joints. It can be used for either wet or dry cutting operations. Being of small construction, it can be transported in a car or van. The water container is enclosed in the frame. All component parts on the BTCS501 are assembled to a high quality standard, ensuring long life, reliability and a minimum of maintenance. Special types of blades are available for asphalt, green concrete, cured concrete (reinforced or not) as well as for industrial cement flooring.

Made of jig welded open profile steel, the BTCS501 is stable but at the same time, easily transportable.

The one-piece blade guard fully protects the operator and his working environment. It is firmly fixed to the main frame but can be opened by rotation to change blades.

A manually operated hand wheel mechanism enables graduated depth setting. Turning the hand wheel clockwise or anti-clockwise will lower or raise the cutting blade.

The pivoting frame, hinged on the rear axle, is supporting the engine, the blade shaft assembly, and the protecting guards. Four heavy-duty belts drive the blade.

The precisely manufactured blade shaft is fitted into two heavy-duty self-aligning pillow block bearings, including grease nipples. A four-belt taper lock pulley is fitted on one end. The shaft is reduced to 25,4mm at the other end, allowing an inner flange complete with dowel pinholes to be fixed.

The steel belt guard is bolted to the mainframe of the machine. It is covering the four drive belts and pulleys for protection of the environment while the machine is running. The pointer allows the operator to make precise cut easily.

The Honda GX390 engine is connected to an emergency shutdown switch on the board of the machine. This allows an immediate stop of the machine in case of danger. The water cooling system is composed of a 70 litres water tank, a water tank tap and two water nozzles on the blade guard ensuring adequate flow of water to both sides of the blade.

2.3 Technical data

Engine	Honda GX390, 4 strokes, 1 cylinder, 13HP (9,6kW)
Fuel	Automotive unleaded gasoline
Oil	Honda 4-Stroke, or equivalent high detergent, premium quality motor oil certified to meet or exceed U.S. automobile manufacturer's requirement for service classification SG, SF. (SG, SF designated on the oil container). SAE 10W-30 recommended
Starter	Manual pull chord
Air filter	Dual type (machine type 99277, 99556, 99557, and 99558) Cyclone type (machine type 99939)
Max. blade diameter	500 mm
Bore	25,4 mm
Max. cutting depth mm	190 mm
Flange diameter	115 mm
Blade shaft speed	2600 min ⁻¹
Driving belts	4
Water tank	70 l
Machine dimensions (length x width x height)	1088x580x925mm
Weight	140 kg
Max. operating weight	220 kg
Sound pressure level	89 dB (A) following ISO EN 11201
Sound energy level	105 dB (A) following ISO EN 3744

3 Assembly and commissioning

Before beginning the work with the BTCS501, you have to assemble some parts.

3.1 Tool assembly

Only use professional blades with the BTCS501.

A blade with a maximum diameter of 500 mm can be fitted. All tools used must be selected with regard to their maximum permitted cutting speed for the machine's maximum permitted rotation speed.

Before mounting a new blade, switch the machine off.

To mount a new blade, follow these steps:

Turn the wheel until the cutting head is in the raised position.

Loosen the screw maintaining the blade guard with the 19mm wrench, and turn it open.

Loosen the hexagonal nut, which holds the removable outer flange with the 36mm wrench.

Remove the outer flange.

Clean the flanges and blade shaft and inspect for wear.

Mount the blade on the shaft ensuring that direction of rotation is correct. Wrong direction of rotation blunts the blade quickly.

Replace outer blade flange.

Tighten hexagonal nut with spanner supplied for this purpose.

Close the blade guard.

The blade bore must correspond exactly to the blade shaft. Cracked or damaged bore is dangerous for the operator and for the machine.

3.2 Water cooling system

Fill the water tank with clean water.

Open water-tap (note that handle on water-tap should be in line with water-flow).

Ensure that water is flowing freely in the circuit and delivered adequately to both sides of the blade, as insufficient water supply may result in premature failure of the diamond blade.

In case of frost, empty the water cooling system

3.3 Starting the machine

Make sure the blade is raised clear up the ground before starting the machine.

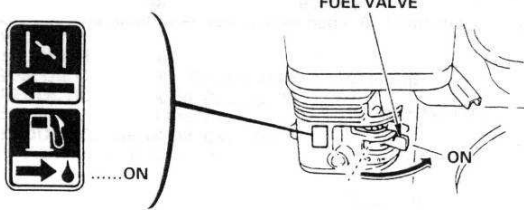
	
<p>Turn the fuel valve to the ON position.</p>	<p>Move the choke lever to the CLOSED position. NOTE: do not use the choke if the engine is warm or the air temperature is high.</p>

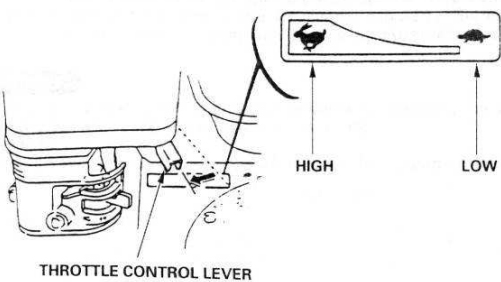
	
<p>Move the throttle control lever slightly to the left.</p>	<p>Put the engine switch on ON, and make sure the emergency switch on the board of the machine is in the correct position.</p>

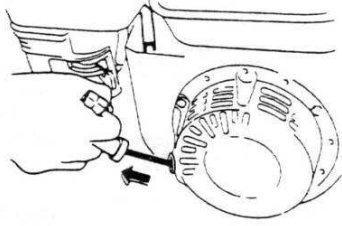
	
<p>Pull the starter grip lightly until you feel resistance, then pull briskly. CAUTION: Do not allow the starter grip to snap back against the engine. Return it gently to prevent damage to the starter.</p>	<p>As the engine warms up, gradually move the choke lever to the OPEN position. Position the throttle control lever for the maximum engine speed.</p>

To stop the engine, move the throttle control lever fully to the right, then turn the engine switch to the OFF position. Turn the fuel valve to the OFF position

4 Transport and Storing

Take the following measures in order to transport and store the BTCS501 securely

4.1 Securing for transport

Before transporting the machine:

- Remove the blade.
- Empty the water tank.
- Raise the guide-a-cut in its upright position.
- Raise the cutting frame to its highest position using the handwheel.

4.2 Transport procedure

The machine can be moved on a flat surface using its wheels. Use the metal hook located on the board of the machine over the motor to move the machine with a crane.

4.3 Long period of inactivity

If the machine is not going to be used for a long period, please take the following measures:

- Completely clean the machine.
- Loosen the drive belts. Grease the threaded shaft. Possibly change the motor oil. Empty the water system.

The storage site must be clean, dry and at a constant temperature

5 Operating the BTCS501

5.1 Site of work

Before you start working, please check the following points:

- Remove from the site anything, which might hinder the working procedure.
- Make sure the site is sufficiently well lit.
- Make sure you have a continual adequate view of the working area so you can intervene in the working process at any time.
- Keep other staff out of the area, so you can work securely.

5.2 Cutting method

5.2.1 Preparing your cut

Before starting the machine,

Draw a line on the floor over the cutting length.

Make sure you have filled the engine tank with fuel, and the water tank with water. No petrol is supplied with the machine.

The engine is shipped with oil. Check oil level before starting. Top up if required.

Make sure you have mounted the correct blade as recommended by the manufacturer depending on the material to be worked, the working procedure (dry or wet cut) to be carried out, and the efficiency required.

Make sure that the flanges securely hold the diamond blade.

Make sure that the blade is not touching the floor before starting.

Roll the machine until the blade is over the line.

Lower the guide-a-cut so it touches the line.

5.2.2 Cutting the floor

You can now start the engine.

To make your cut,

Turn the depth hand wheel until the blade slightly touches the floor.

Open water valve to control the amount of water required for the type of blade, using 15 to 25l/min for wet and 1-2l/min for dry cutting, dust control. Check for minimum water level regularly.

turn the hand wheel to lower blade into the cut.

Once the required depth of cut is reached, push the machine forward with steady and gentle pressure and follow the line with the pointer. The feed speed must be adjusted depending on the material being cut, and depth of cut.

At the finish of the cut, raise the blade out of the cut by turning the hand wheel, switch off the engine and shut-off the water

6 Maintenance and service

ATTENTION : to perform maintenance on the machine, always switch it off. Always wear a face mask and safety goggles while performing the maintenance of machine

6.1 Maintenance of the machine

To ensure a long-term quality from the cutting with the BTCS501, please follow the maintenance plan below:

		After one hour of work	Begin of the day	During the changing of the tool	End of the day	Every week	After a fault	After a damage
Whole machine	Visual control (general aspect, watertightness)							
	Clean							
Flange and blade fixing devices	Clean							
Belts tension	Control							
Water hoses and nozzles	Clean							
Depth screw	Grease							
Engine housing	Clean							
Reachable nuts and screws	Tighten up							

Adjustment and replacement of the belt

After one hour of work, the belts heat and stretch. Therefore, you have to re-tension them.

To adjust the belts, firstly remove the belt guard by unscrewing the 2 nuts. Loose the 2 bolts at the back of the engine-plate and shift the engine by using the screw on the back of the plate to retighten the belts.

To replace the belts, move the engine completely down by unscrewing the screw at the back of the engine-plate. Adjust the belts and retighten them using the screw at the back of the engine plate.

Always use a matched set of belts. Do not replace single belts. After controlling or retightening the belts, reassemble the belt guard on the frame of the machine.

Lubrication

The BTCS501 uses life-lubricated bearings. Therefore, you don't need to lubricate them at all. Grease the depth screw every day.

Cleaning of the machine

Your machine will last longer if you clean it thoroughly after each day of work

6.2 Maintenance of the engine

		Each use	First month or 20 hours	Every 3 months or 50 hours	Every 6 months or 100 hours
Engine oil	Check level				
	Change				
Air cleaner filter	Check				
	Clean				
Fuel strainer cup	Clean				
Spark plug	Check-Clean				
Fuel line	Check (Replace if necessary)				
		Every 2 years			

Engine oil

To change the oil,

Remove the oil filler cap/dipstick and drain bolt.

Allow the oil to drain completely.

Dispose of used motor oil in a manner that is compatible with the environment. We suggest you to take used oil in a sealed container to your local recycling centre or service station for reclamation. Do not throw it in the trash, pour it on the ground or down in a drain.

Reinstall the drain bolt, and tighten it to 18 N.m.

Fill the crankcase with the engine oil to the outer edge of the oil filler neck.

Reinstall the filler cap/dipstick.

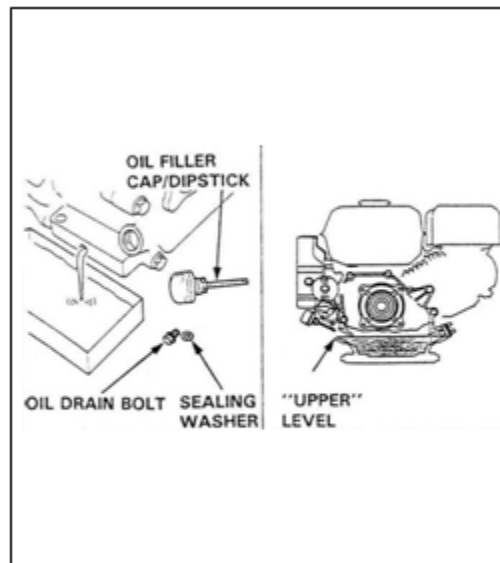

Air cleaner

The BTCS501 has a dual type filter
To service the air cleaner filter, follow these instructions:

Remove the nut, air cleaner cover and wing nut.

Remove the pre air cleaner elements and separate them.

Carefully check both elements for holes or tears and replace if damaged.

Paper element: tap element lightly several times on a hard surface to remove excess dirt or blow compressed air lightly through the filter from the inside out. Never brush the dirt off; brushing will force dirt into the fibres.

Foam element: clean in warm soapy water, rinse and allow to dry thoroughly. Dip the element in clean engine oil and squeeze out all the excess. The engine will smoke during initial start-up if too much oil is left in the foam.

Shine a light through the elements, and inspect them carefully. Reinstall the elements if they are free of holes and tears.

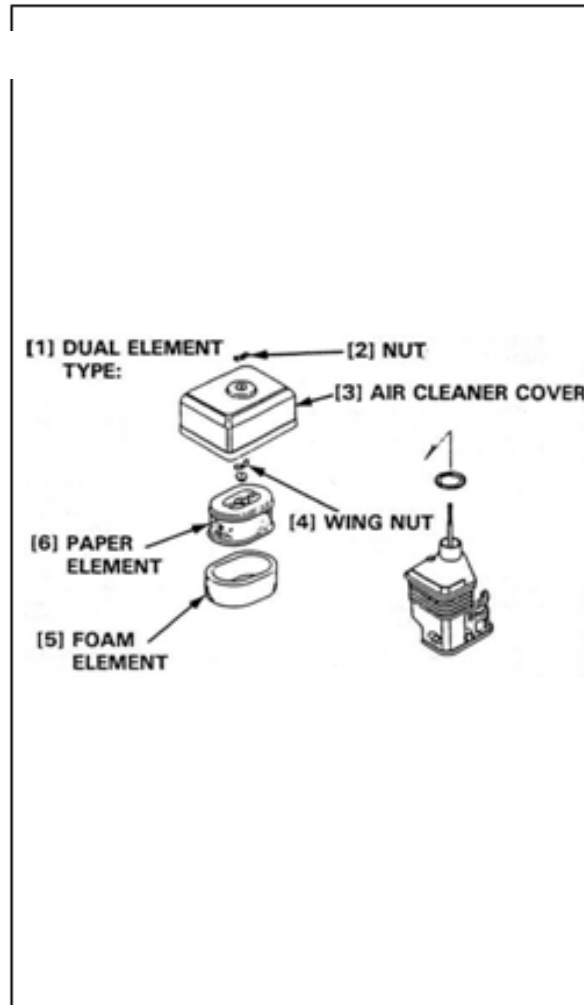

Fuel strainer cup

To service fuel strainer cup, follow these instructions:

Turn off the fuel valve and remove the strainer cup.

Clean the strainer cup with solvent

Install the O-ring and strainer cup.

Tighten the strainer cup to 4N.m.

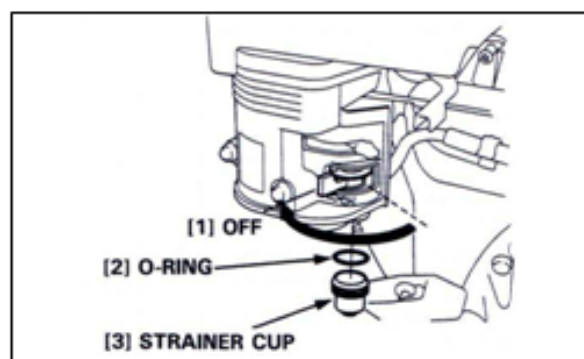

Spark plug

To service the spark plug, follow these instructions:

Visually inspect the spark plug. Discard the plug if the insulator is cracked or chipped.

Remove carbon or other deposits with a stiff wire brush.

Measure the plug gap with a wire-type feeler gauge. If necessary, adjust the gap by bending the side electrode.

Make sure the sealing washer is in good condition; replace the plug if necessary.

Install the plug fingertight to seat the washer, then tighten with a plug wrench (an additional $\frac{1}{2}$ turn if a new plug) to compress the sealing washer. If you are reusing a plug, tighten $\frac{1}{8}$ - $\frac{1}{4}$ turn after the plug seats.

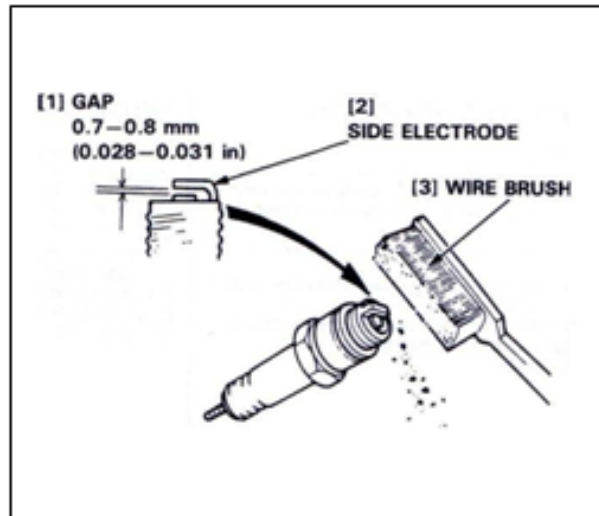

Fuel line

To service the fuel line, follow these instructions:

Drain the fuel into a suitable container, and remove the fuel tank.

Disconnect the fuel line, and unscrew the fuel filter from the tank.

Clean the filter with solvent, and check, that the filter screen is undamaged.

Place the O-ring on the filter and reinstall. Tighten the filter to 2N.m. After reassembly, check for fuel leaks.

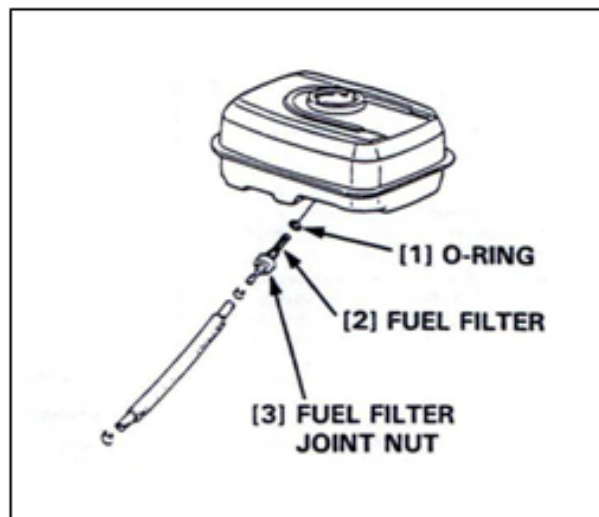

Further maintenance

For further maintenance, please contact the nearest engine maintenance centre.

7 Faults: causes and cures

7.1 Fault-finding procedures

Should any fault occur during the use of the machine, turn it off. Let only qualified staff make any intervention other than the one described in the previous section.

7.2 Trouble-shooting guide

Trouble	Possible source	Resolution
Hard starting	Not enough fuel	Fill fuel tank
	Fuel filter clogged	Clean fuel filter
	Spark plug faulty	Inspect spark plug
	Stronger fault	Contact nearest engine maintenance centre
Engine lacks power	Air filter restricted	Clean or replace air filter
	Stronger fault	Contact nearest engine maintenance centre

7.3 Customer service

When ordering spare parts, please mention:

The serial number (7 digits).

The code of the part.

The exact denomination.

The number of parts required.

The delivery address.

Please indicate clearly the means of transportation required such as "express" or "by air". Without specific instructions, we will forward the parts through the means which seem appropriate to us and but which is not always the quickest way.

Clear instructions will avoid problems and faulty deliveries.

If not sure, please send us the defective part.

In the case of a warranty is claim, the part must always be returned for evaluation.

Spare parts for the engine can be ordered with the manufacturer of the engine or with their dealer, which is often quicker and cheaper.

8. PARTS

BLADE GUIDE & WATER SYSTEM

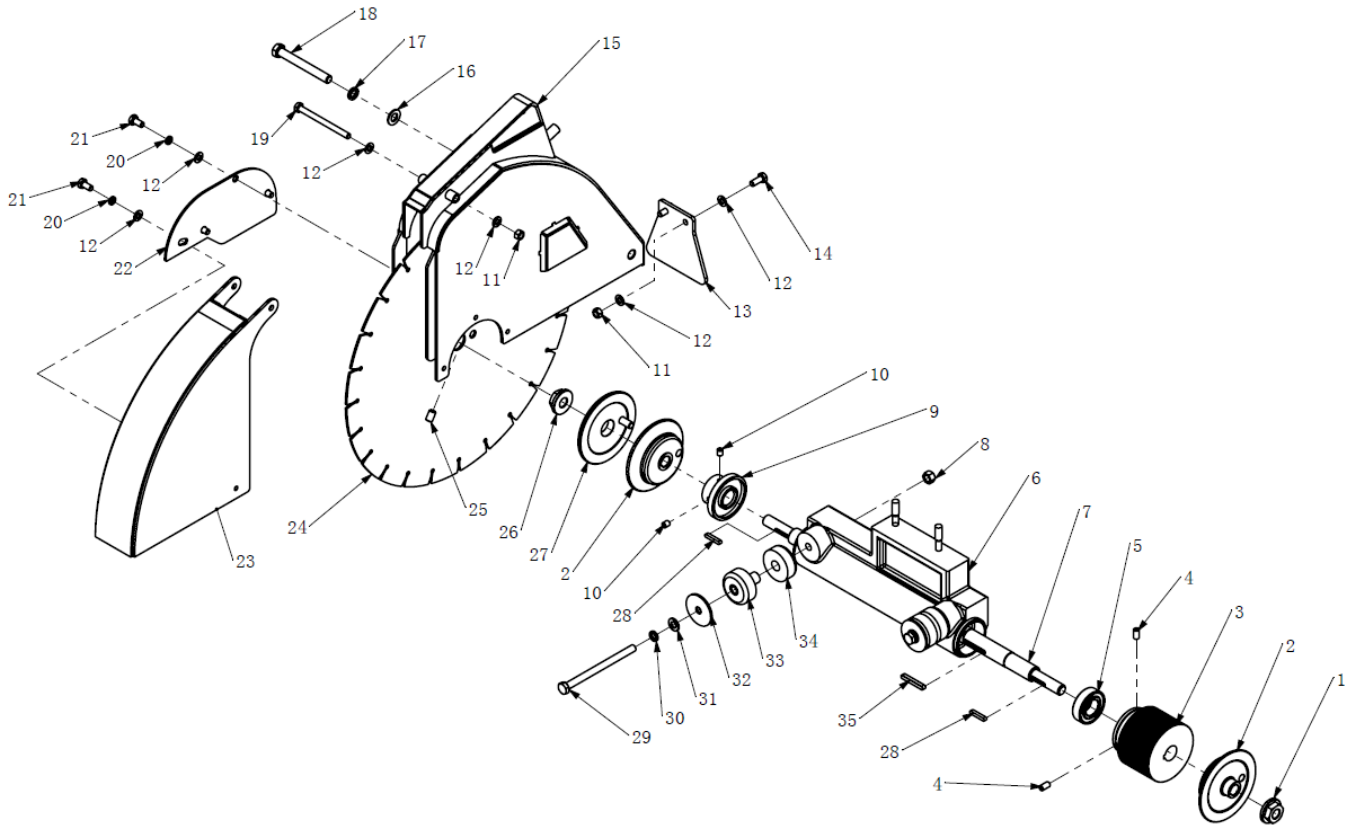

BLADE GUIDE & WATER SYSTEM			
Item	Description	Part No.	QTY
1	FLANGE NUT (LEV)	0905-03006-1	1
2	FLANGE	0905-03003-1	2
3	BLADESHAFT PULLEY	0905-03002-1	1
4	BEARING 6205	136025	2
5	BLADESHAFT	0905-03001-1	1
6	NYLON NUT M10	4100001	2
7	BLADESHAFT TUBE MACHINING	0905-03100-1	1
8	SLINGER. BLACK OXIDE	0905-03004-1	1
9	PLAIN FLANGE	0905-03200-1	1
10	FLANGE NUT (DEX)	0905-03005-1	1
11	BLADE GUARD REAR	0905-01100-3	1
12	WATER PIPE KIT	0905-13000-1	1
13	WASHER M12	1120000	1
14	SW M12	2120000	1
15	BOLT M12X100X25	31210025	1
16	WASHER M8	1080000	6
17	BOLT M8X100X25	30810025	1
18	BOLT M8X16	3081600	4
19	SW M8	2080000	4
20	BLADE GUARD CONNECTOR	0905-01001-2	1
21	BLADE GUARD FRONT	0905-01200-3	1
22	SAW DISC	16140000	1
23	NYLON NUT M8	4080001	1
24	BOLT M10X130X35	31013035	2
25	WASHER	1115003	2
26	SHOCK ABSORBER (IN)	0905-00001-1	2
27	SHOCK ABSORBER (OUT)	0905-00014-1	2
28	KEY 6X45	12060645A	1
29	KEY 5X30	12050530A	1

MOTOR & WATER TANK

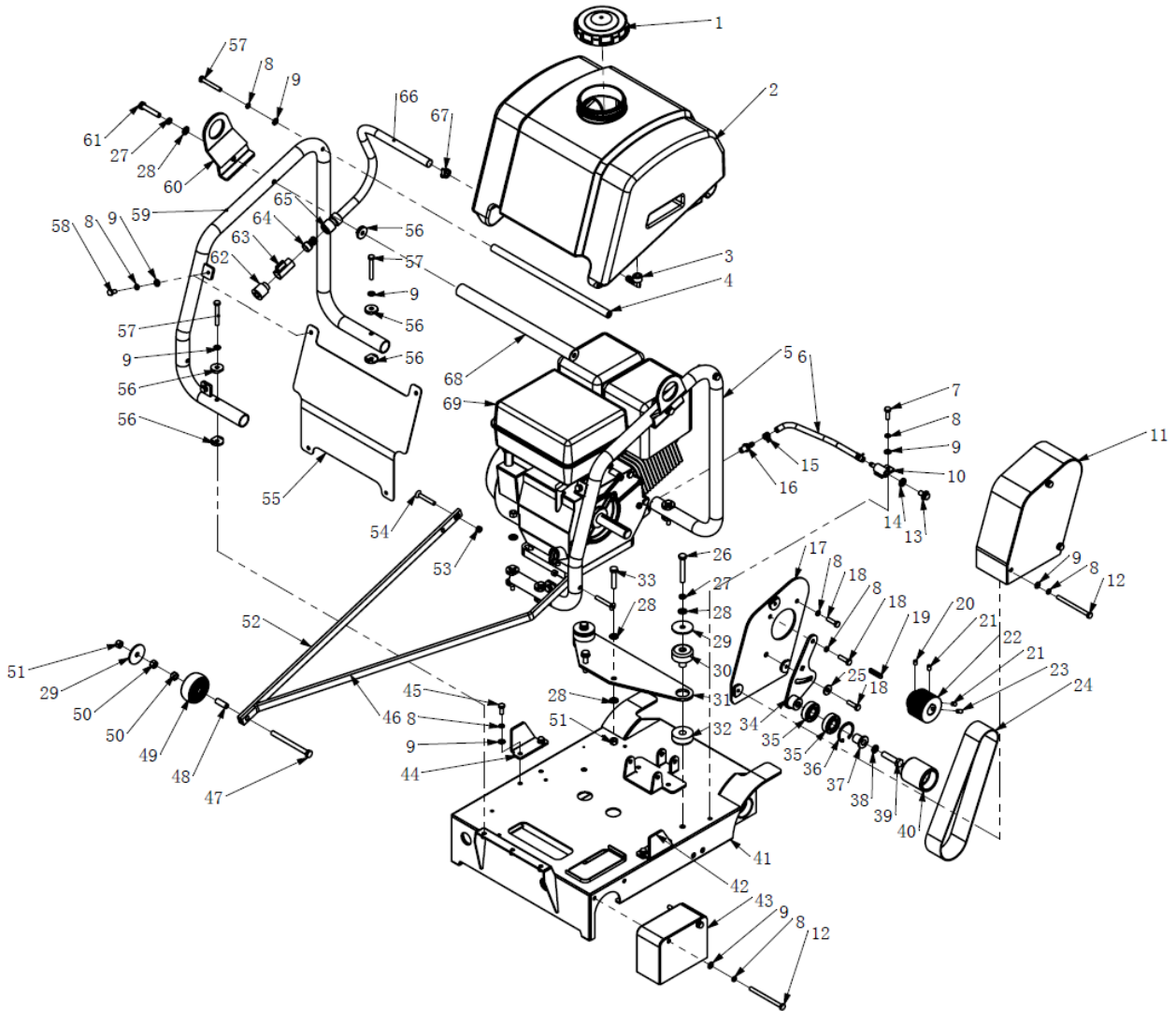

MOTOR & WATER TANK			
Item	Description	Part No.	QTY
1	WATER TANK CAP	0904-09100-4	1
2	WATER TANK	0905-00006-1	1
3	FITTING	0904-00007-1	1
4	U-BOLT	0905-08005-1	1
5	NUT M10	4100000	4
6	WASHER	0905-08006-1	4
7	BAR. LIFTING BAIL	0905-08003-1	1
8	BAR. TANK PIVOT	0905-08007-1	1
9	ENGINE CAGE. LEFT	0905-11000-1	1
10	ENGINE GX390	17390	1
11	BOLT M10X70X26	3107026	2
12	SW M10	2100000	2
13	WASHER Φ 11X50X3	1115003	3
14	SHOCK ABSORBER (IN)	0905-00001-1	2
15	ENGINE PLATE	0905-07001-2	1
16	SHOCK ABSORBER (OUT)	0905-00014-1	2
17	BELT GUARD PLATE	0905-06200-3	1
18	ENGINE PULLEY	0905-07004-1	1
19	SW M8	2080000	19
20	BOLT M8X30	3083000	2
21	KEY 8X40	12080740B	1
22	WASHER M8X24	1082420	1
23	BOLT M8X25	3082500	1
24	BELT COVER ASSY	0905-07200-1	1
25	BOLT M8X105X20	30810520	3
26	WASHER M8	1080000	22
27	TENSION ROLLER	0905-07002-1	1
28	BOLT M12X50X30	3125030	1
29	SW M12	2120000	1
30	TENSION ROLLER SHAFT	0905-07003-1	1
31	CIRCLIP	9470002	1
32	BEARING 6204	136204	2
33	TENSION ROLLER PLATE	0905-07100-1	1

34	BOLT M8X100X25	30810025	2
35	SHAFT GUARD	0905-03300-3	1
36	FRAME. WELDMENT	0905-02100-3	1
37	SPADE, BLADE GUIDE (LEFT)	0905-02002-2	1
38	SPADE, BLADE GUIDE (RIGHT)	0905-02001-2	1
39	BOLT M8X20	3082000	8
40	BOLT M10X50X30	3105030	2
41	WASHER M10	1100000	6
42	NYLON NUT M10	4100001	7
43	BOLT M10X120	31012000	1
44	BUSHING	0905-00009-1	1
45	WHEEL	17129032	1
46	POINTER SUPPORT	0905-09002-2	1
47	POINTER	0905-09001-2	1
48	NYLON NUT M8	4080001	2
49	WATER TANK WASHER	0905-08004-1	16
50	SOCKET HEAD BOLT M8x55	708550005	2
51	BOLT M8X55X25	3085525	9
52	ENGINE CAGE. RIGHT	0905-12000-1	1
53	FRONT COVER	0905-00019-1	1
54	FITTING	0904-09005-4	1
55	ROBINET MINU-LUX	0904-09004-4	1
56	ADAPT RAPIDE MALE	0904-09003-4	1
57	RACCORD PARIDE LAITON	0904-09002-4	1
58	WATER PIPE	0905-00005-1	1
59	BELT	0905-00020-1	1

CRANK

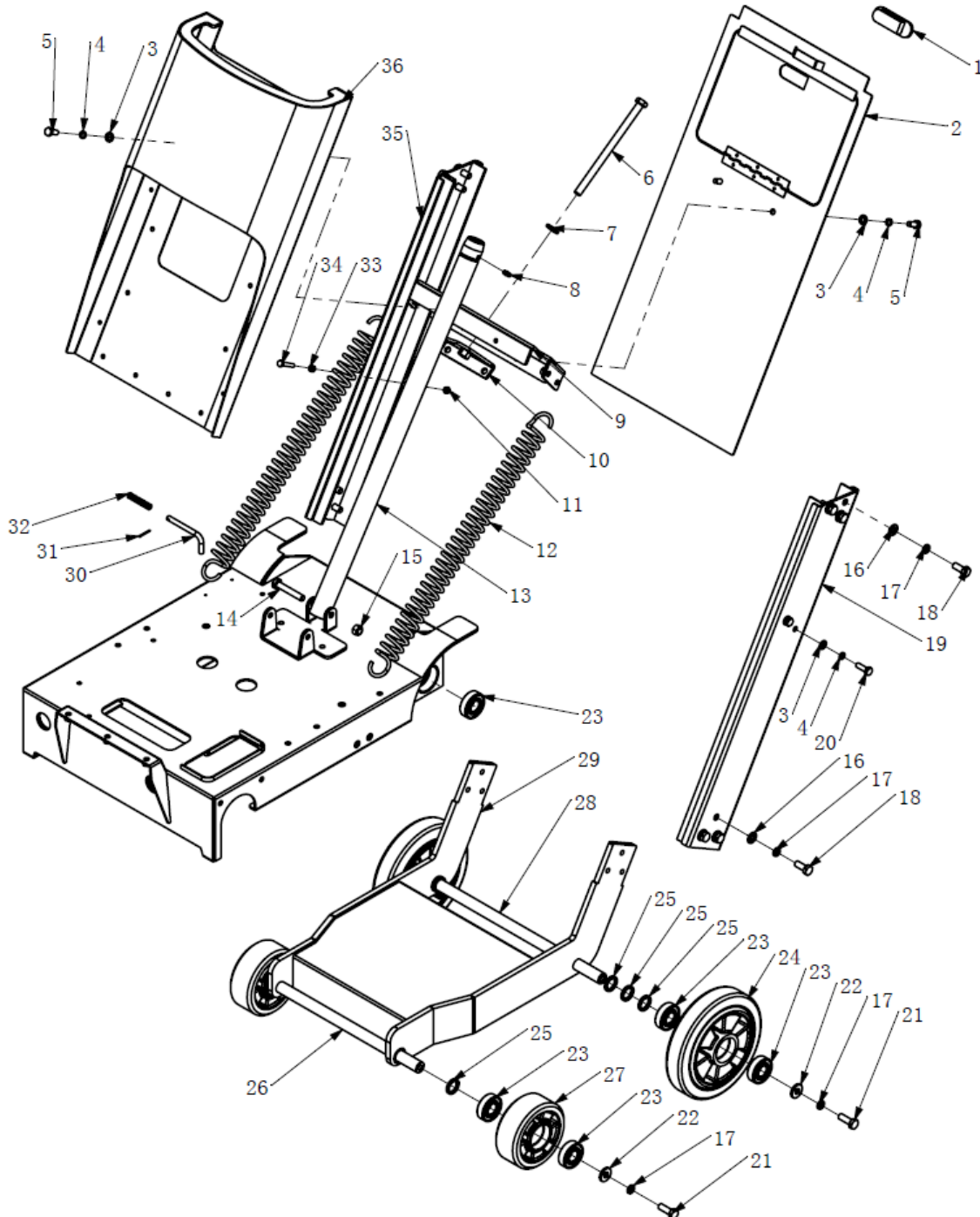

CRANK			
Item	Description	Part No.	QTY
1	SIDE RIGHT	0905-04900-3	1
2	WELDMNT. NUT TUBE	0905-05100-3	1
3	COLLAR. SCREW	0905-05002-1	1
4	BOLT M8×10	3081000	1
5	GREASE NOZZLE	0905-00012-1	1
6	WASHER M12	1120000	1
7	SW M12	2120000	1
8	BOLT M12X190	31219000	1
9	WASHER M8	1080000	16
10	SW M8	2080000	16
11	BOLT M8X25	3082500	8
12	SIDE LEFT	0905-41000-3	1
13	COVER. WLDMNT. TOOLBOX	0905-04200-2	1
14	TOOLBOX LOCK	0905-00017-1	1
15	BOLT M8X20	3082000	4
16	BOLT M8X30	3083000	4
17	NYLON NUT M10	4100001	1
18	BEARING	136204	10
19	WASHER Ø20X28X3	0905-06005-2	8
20	REAR WHEEL AXLE	0905-06002-1	1
21	WHEEL	174720060	2
22	WASHER M10X25X2.5	1102525	4
23	SW M10	2100000	4
24	BOLT M10X30	3103000	4
25	WHEEL	174712450	2
26	FRONT WHEEL AXLE	0905-06001-1	1
27	CARRIAGE	0905-04100-3	1
28	BREAK PIN	0905-06003-1	1
29	PIN	11162000	1
30	BREAK SPRING	0905-00011-1	1
31	BOLT M10X60X30	3106030	1
32	CHASSIS	0905-02100-3	1
33	SPRING	145540305	2

34	SPRING SUPPORT ASSY	0905-04400-3	1
35	NYLON NUT M6	4060001	1
36	SOCKET HEAD SCREW M6X45X20	706452003	1
37	PLATE. RIVET	0905-04300-2	1
38	COVER. CONSOLE	0905-04800-3	1
39	BACK COVER	0905-04202-2	1
40	SCREW	7051601	6
41	PLATE, RUBBER MAT	0905-04204-2	2
42	RUBBER MAT	0905-04203-2	1
43	NYLON NUT M5	4050001	6

HANDLE

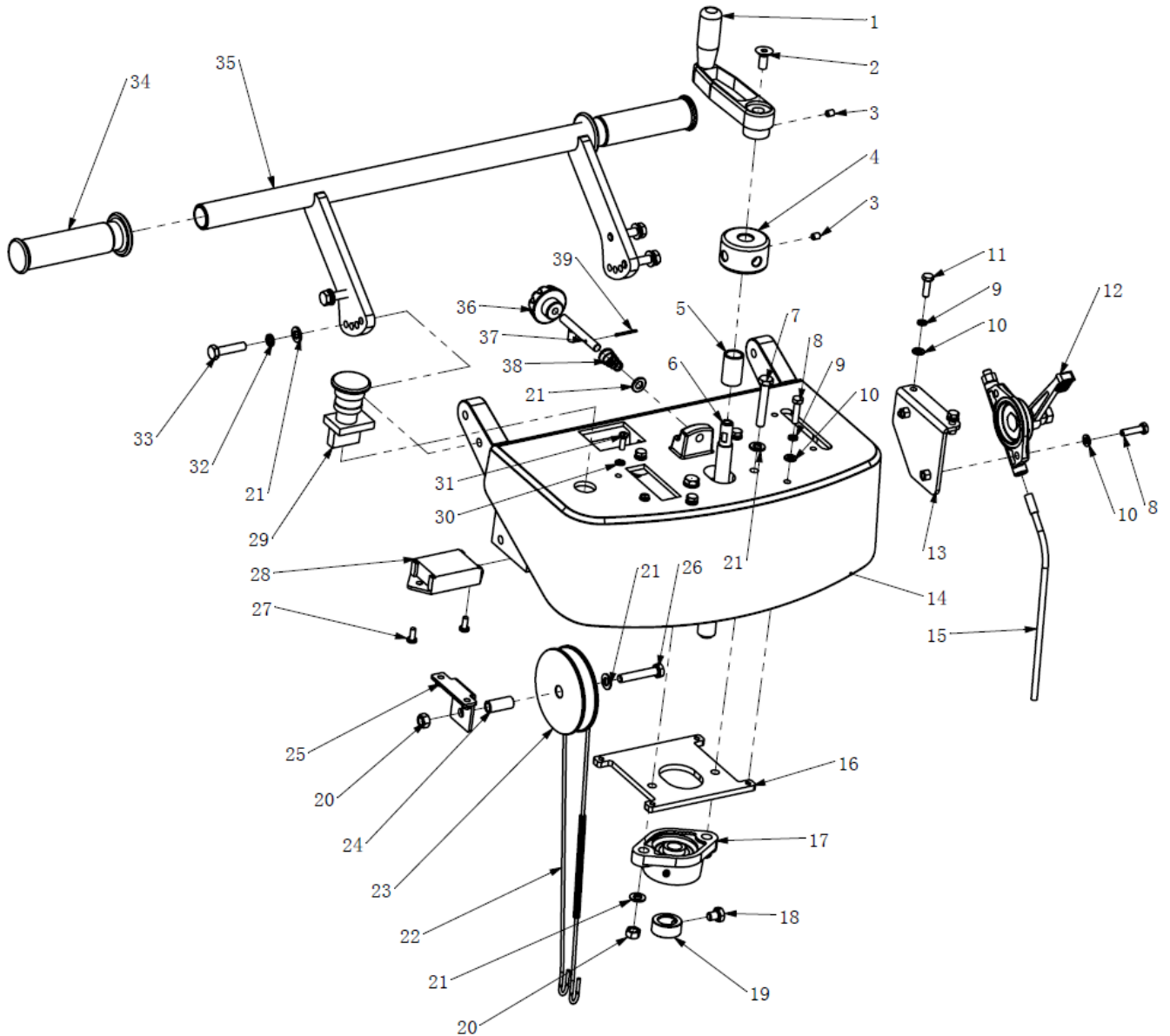

HANDLE			
Item	Description	Part No.	QTY
1	ROOLIRATAS	0905-00010-1	1
2	BOLT M8X20	3082000	1
3	WASHER M8	1080000	11
4	SCREW M4X8	7040804	1
5	HANDLE SUPPORT	0905-05006-2	1
6	SCREW M6X8	706080004	1
7	SPACER	0905-05003-1	1
8	BOLT M6X20	3062000	4
9	SW M6	2060000	8
10	WASHER M6	1060000	8
11	THROTTLE LEVER ASSY	R66-002	1
12	THROTTLE LEVER SUPPORT	0905-00002-1	1
13	NUT M6	4060000	4
14	BOLT M6X25	3062500	4
15	DECAL	0905-04004-1	1
16	BOLT M8X55X25	3085525	2
17	SCREW. ADJ.	0905-05001-1	1
18	BOLT M8	0905-00016-1	1
19	BRACKET	0905-05004-2	1
20	BEARING	13UCFLU202	1
21	NYLON NUT M8	4080001	3
22	DEPTH GAUGE CABLE ASSY	0905-04006-1	1
23	WHEEL. DEPTH GAUGE	0905-04005-1	1
24	BRACKET. DEPTH GAUGE	0905-04700-3	1
25	SUNK HEAD SCREW M5X12	7051201	2
26	SW M5	2050000	2
27	HOUR METER	0905-00018-1	1
28	WASHER M5	1050000	2
29	SUNK HEAD SCREW M5X16	7051601	2
30	STOP SWITCH	0905-00015-1	1
31	SW M8	2080000	4
32	BOLT M8X35	3083500	4
33	HANDLE	0905-04500-3	1



Beton Trowel nv

34	GRIP	17010000	2
35	WING BOLT	0905-05304-3	1
36	DOWEL PIN	0905-05300-3	1
37	SPRING	0905-05005-2	1
38	SPRING PIN	11252500	1

Nijverheidsstraat 10
1840 Londerzeel/Belgium
Tel: +32 (0)52 315 350 - Tel: +32 (0)52 315 351
Fax: +32 (0)52 315 359
E-mail: info@betontrowel.com
BE 0821.249.312
www.betontrowel.com

BNP FORTIS: BE81 0015 9813 5624 - GEBABEBB
ING: BE BBRUBEBB

Declaration of Conformity / Certificat de conformite / Gelijkvormigheidscertificaat / Declaracion de Conformidad / Declaracao de Concormidade / Dichiarazione Di Conformita

Model : BTCS501

We Beton Trowel NV

Declare under our sole responsibility that the product to which this declaration relates is in conformity with the following standards or other normative documents.

Declarons sous notre responsabilite que le produit cette declaration est conforme aux norms suivantes ou d'autres documents habituels.

Verklaren onder onze verantwoordelijkheid dat het product naar welke de verklaring verwijst conform de volgende standards of anders gebruikelijke documenten is.

Declaramos bajo nuestra unica responsabilidad que el producto en lo que esta declaracion concierne, es conforme con la siguiente normative u otros documentos.

Declara sob sua responsabilidade que o produto a quem esta declaracao interessar, esta em conformidade com os seguintes documentos legais ou normas directivas.

Dichiariamo sotto la ns. Unica responsibilita che il prodotto al quale questa dichiarazione si riferisce, e fabbricato in conformita ai seguenti standard e documenti di normative.

EN 349:2008:A1:2008 EN 12100:2010 EN12649:2008+A1:2011 EN ISO 5349-2:2001 +A1:2015

Following the provisions of Directives:

Suivant les directives determinees:

Volgens de vastgestelde richtlijnen:

Siguiendo las directivas:

No sequimento das clausulas da Directivas

Seguendo quanto indicato dalla Direttivas:

2006/42/EC Machinery Directive

2000/14/EC Noise Directive

2001/95/EC General Product Safety Directive

2002/95/EC Reduction of Hazardous Waste Directive

LVD2014/35/EU Low Voltage Directive

2004/30/EU Electromagnetic Compatibility



Responsible Technical File : Chris Livingston for

Beton Trowel NV

Nijverheidsstraat 11

B-1840 Londerzeel

Belgium

Tel 0032 52315350

Fax0032 52303739

01/08/2019